

Service Rig Inspection Manual

April 8, 2020

As part of its contributions towards the Government of Alberta's *Red Tape Reduction Act*, the following changes have been made to this directive:

- The 2018 addendum *Well Control and Well Blowout Prevention Training* has been brought into the directive and rescinded.
- Text stricken through in 2016 as part of the *Integrated Compliance Enforcement Framework* project has been deleted.
- References to legislation in section 105 have been updated.
- Section 115 has been rescinded.
- Duplicated requirements in section 225 regarding Class II and Class IIA wells have been merged.
- Appendix 1060 has been rescinded.

The directive has not yet been fully rebranded. The caveats listed on the following cover page still apply.

Directive 037: Service Rig Inspection Manual

February 2006

Effective June 17, 2013, the Energy Resources Conservation Board (ERCB) has been succeeded by the Alberta Energy Regulator (AER).

As part of this succession, the title pages of all existing ERCB directives now carry the new AER logo. However, no other changes have been made to the directives, and they continue to have references to the ERCB. As new editions of the directives are issued, these references will be changed.

Some phone numbers in the directives may no longer be valid. Contact AER Inquiries at 1-855-297-8311 or inquiries@aer.ca.

GUIDE RENAMED AS A DIRECTIVE

As announced in *Bulletin 2004-02: Streamlining EUB Documents on Regulatory Requirements*, the Alberta Energy and Utilities Board (EUB) will issue only “directives,” discontinuing interim directives, informational letters, and guides. Directives set out new or amended EUB requirements or processes to be implemented and followed by licensees, permittees, and other approval holders under the jurisdiction of the EUB. As part of this initiative, this document has been renamed as a directive.

The document text continues to have references to “guides.” These references should be read as referring to the directive of the same number. When this directive is further amended, these references will be changed to reflect their renaming as directives.

The Alberta Energy and Utilities Board (EUB/Board) has approved this directive on February 16, 2006.

<original signed by>

B. T. McManus, Q.C.

ALBERTA ENERGY AND UTILITIES BOARD Directive 037: Service Rig Inspection Manual

February 2006

Replaces Guide 37: Service Rig Inspection Manual (June 1995)

Published by

Alberta Energy and Utilities Board
640 – 5 Avenue SW
Calgary, Alberta
T2P 3G4

Telephone: (403) 297-8311
Fax: (403) 297-7040

Web site: www.eub.gov.ab.ca

Contents

Guide to Manual	1
015: About This Manual.....	1
015-2: Electrical Inspections of Service Rigs.....	1
020: Using the Manual	3
100: Policies.....	3
105: EUB Responsibilities	3
110: Conduct	6
120: Industry/Government Involvement	6
200: Conducting the Inspection	7
205: Arrival at the Well Site.....	7
210: BOP System Requirements and Specifications.....	7
215: BOP Controls	13
220: Crew Training and Certification.....	14
225: BOP Mechanical Test.....	16
230: Air Shut-offs/Diesel and Gasoline Engine Spacing	20
235: Accumulator Sizing and Operating Policies.....	22
240: Back-up Nitrogen Supply.....	29
245: Winterizing BOP Equipment.....	35
250: Spacing Regulations	36
255: Handling Sour Effluent.....	37
260: BOP Pressure Test.....	38
265: Well-Site Conditions	40
270: Operator and Contractor Inspections.....	42
280: Smoking.....	45
300: Completing the Inspection Report	46
305: General Information	46
310: Mechanical Tests.....	47
315: Inspection Results.....	48
320: Remedial Action.....	50
325: Signatures and On-Site Discussions.....	54
330: Special Wells.....	55
1000: Appendices.....	55
1005: Sample Inspection Reports.....	55
1010: Well Servicing Equipment Code	59
1025: Accumulator Sizing Calculations – Alternate Method.....	64
1030: Back-Up Nitrogen Calculations – Alternate Method	65
1035: EUB Crew Training Assessment Form	68
1040: EUB Crew Procedures Form.....	69
1045: Operational Deficiencies	73
1055: BOP Fluid Volumes	81
1070: Drilling with a Service Rig.....	94
1080: Coiled Tubing Requirements.....	94
1090: BOP Modification Submission.....	95
1100: Oilfield Waste Management Inspection Guidelines – Drilling Operations.....	95

Guide to Manual

015: About This Manual

Purpose of Manual

This manual is designed to assist EUB employees and others who inspect service rigs.

Inspectors should use this manual as a reference during inspections. It anticipates questions that may arise in interpreting regulations.

The manual is divided into three main sections:

1. EUB policy related to inspections.
2. Detailed instructions and criteria for conducting the inspection.
3. Detailed instructions explaining each item on the inspection report.

AOH&S Legislation

The manual includes AOH&S legislation with respect to drilling rig safety (Appendix 1060). Its inclusion is intended to inform users of this manual of the regulations that should be considered in the overall safety performance at drilling sites.

EUB inspectors should become familiar with AOH&S legislation and be prepared to

- alert operators and/or contractors regarding unsafe operating practices.
- advise AOH&S and EPB of unsafe operating practices noted during rig inspections.

EUB inspectors may periodically note differences between EUB and AOH&S equipment spacing requirements. During such occasions, the EUB requirements take precedence.

015-2: Electrical Inspections of Service Rigs

Electrical Protection Branch Legislation

This document is intended to describe and formalize the roles and expectations of the EUB and Alberta Labour with regards to electrical conditions at rigs. It is important to note that all jurisdiction of electrical systems at rigs remains with Alberta Labour. Included in this document is a discussion of the background and goals which have to be met to achieve a satisfactory agreement.

Roles and Expectations

EUB inspectors conduct inspections of rigs to ensure compliance with EUB requirements. They are not inspecting the electrical systems on those rigs. However, if during the EUB inspection an

*obvious problem with the electrical system is noted, the inspector will write the following reminder on the EUB rig inspection form. A copy of that form will be forwarded to Alberta Labour at the address listed at the end of this agreement.

* obvious problem: because of the lack of formal electrical training of EUB staff, obvious problems are considered to be electrical systems with signs of poor maintenance such as tattered and frayed cords, numerous light protectors missing, and evidence of shorting or sparking.

It is the responsibility of the contractor to ensure electrical compliance and there will be no follow-up on these reminders by EUB staff. However, repeat electrical problems would be followed up by Alberta Labour as they will have copies of all such reminders forwarded to them by EUB inspectors.

Background

Alberta Labour staff do not normally inspect electrical systems on rigs after the rigs are in service. They are concerned that rigs, with their constant moving, are prone to electrical system deterioration. EUB staff, though they have no formal training in electrical systems, inspect rigs at regular, if infrequent, intervals. It is felt that EUB staff could help Alberta Labour by reminding personnel, at rigs with questionable electrical systems, of their responsibilities and informing Alberta Labour. EUB has no jurisdiction to enforce any requests for remedial work on electrical systems.

Goals of This Agreement

1. To help ensure that electrical systems on rigs are maintained according to the Safety Codes Act.
2. To coordinate “government inspections”, efficiently reduce duplication, and facilitate government agencies' aid to each other.
3. To emphasize the fact that EUB staff, while willing to help, are not trained specialists in the area of electrical inspections, and that in no way should their inspection be construed as a complete and thorough inspection of the electrical system.
4. To ensure that it is understood that, by this willingness to help, the EUB is in no way assuming jurisdiction of electrical systems.
5. To ensure that the EUB and its staff are protected from the potential of court actions as a result of trying to help out a member of our government family.

Ken McLennan, Sr. Technical Advisor
Alberta Labour
8th Floor, 10808 - 99 Avenue
Edmonton, AB T5K 0G5

Bill Remmer, Field Operations
Alberta Energy and Utilities Board
640 - 5 Avenue SW
Calgary, AB T2P 3G4

020: Using the Manual

Preliminaries

1. Review the Table of Contents to become familiar with the organization of the manual.
2. Read and study the manual to become familiar with its contents.

References

3. An inspector should be totally familiar with the manual's inspection procedures, policies, and technical data before embarking on any service rig inspections.

Non-EUB Users

4. While every effort has been made to ensure the accuracy and reliability of the technical data presented in this manual, the EUB does not guarantee the data and hereby disclaims responsibility for loss or damage resulting from its use. It is the responsibility of the user to verify the data provided.

Waivers

5. Operators who wish to be exempt from any requirement of this manual, must submit a request for waiver of the section involved to the Drilling and Production Department, EUB, Calgary. Waivers that result in major modifications to BOP components or procedures will not be granted by the Area Office.

100: Policies

105: EUB Responsibilities

The Alberta Energy and Utilities Board's responsibilities with respect to well servicing are

1. according to the *Energy Resources Conservation Act* (section 2(d)(e)),

“to control pollution and ensure environment conservation in the exploration for, processing, development and transportation of the energy resources and energy,”

“to secure the observance of safe and efficient practices in the exploration for, processing, development and transportation of the energy resources of Alberta,”

2. according to the *Oil and Gas Conservation Act* (Part 1, section 4(b)(d)(f)),

“to secure the observance of safe and efficient practices in the locating, spacing, drilling, equipping, completing, reworking, testing, operating and abandonment of wells and in the operations for the production of oil, gas and crude bitumen,”

“to afford each owner the opportunity of obtaining their share of the production of oil or gas from any pool or of crude bitumen from any oil sands deposit,”

“to control pollution above, at or below the surface in the drilling of wells and in operations for the production of oil, gas and crude bitumen and in other operations over which the Board has jurisdiction.”

3. According to section 8.149(1) of the *Oil and Gas Conservation Rules*,

“The Regulator or its authorized representative may make a direction requiring the licensee of the well to (a) test the operation and effectiveness of blowout prevention equipment required by Directive 036 and Directive 037, (b) conduct a pressure test of the blowout prevention equipment referred to in clause (a), using where necessary a hanger plug or casing packer, and (c) perform a blowout prevention drill.”

**Purpose of Rig Inspections
The Inspectors Role**

The EUB inspectors role is to encourage cooperation with the Contractor and Licensee representatives, with the aim of improving their understanding and commitment towards meeting the inspection requirements and regulations.

Where it becomes obvious that such commitment is lacking and an open disregard for the Board's requirements is displayed, a system of escalating consequences will be imposed by the EUB. This will be in keeping with our “firm but fair” approach to all our customers.

In an effort to be efficient in the use of the Board's resources, the following criteria may be used in determining which rigs will be inspected.

In an effort to be efficient in the use of the Board's resources, the following criteria may be used in determining which rigs will be inspected.

1. Inspection History of the Rig Contractor and Operator.
 - Previously noted unsatisfactory items or requests for remedial action should be followed up.
2. On-Site Assessment of Drilling Occurrence Information.
 - Are there any instances of kicks, blows, blowouts, documented for the area the rig is working in and are the on-site personnel aware of them.

3. Approvals, Directives.

- Are there any new policies or requirements which may need to be addressed during the inspection.

4. Focus.

- The inspector should thoroughly evaluate equipment, procedures and operating policies on-site including:
 - crew training, - kick prevention, detection, control
 - well control information
 - servicing program
 - offset well data
- The inspector should also be receptive to:
 - concerns and questions regarding regulations or requirements
 - providing additional clarification or information as requested.

An inspector should be prepared to initiate additional discussion or request additional crew training if during the inspection there is evidence it is required.

Industry's Role

The licensee and their contractors should understand, respect, meet or exceed the servicing regulations, recommended practices and standards.

This is achieved by the implementation of:

1. Internal inspection, compliance programs, and being aware of their company EUB inspection record, and taking appropriate action where necessary.
2. Ongoing training of wellsite personnel. For safety, well control and equipment.
3. Informing on-site personnel of potential hole problems, sensitive environmental and public issues, in order to ensure appropriate responses are implemented.
4. Cooperation with the EUB, government and public by the open exchange of dialogue to address areas of mutual concern.

110: Conduct

Each inspector is an official representative of the Board.

When at a well site and when performing any function under the Board's responsibility, the inspector shall conduct himself/herself in a business-like and professional manner.

Each inspector must display a positive attitude, job knowledge, tact, fairness, and discretion to earn industry's respect for the Board and its inspectors.

Historically, Board staff have achieved compliance with the regulations through co-operation with industry rather than through confrontation. Each inspector should continue to foster this working relationship.

120: Industry/Government Involvement

Most of the regulations currently in effect for well servicing were endorsed by the Independent Petroleum Association of Canada and the Canadian Petroleum Association before being proclaimed.

The EUB service rig inspection policies and procedures contained in this manual were endorsed by the Canadian Association of Petroleum Producers, Canadian Association of Oilwell Drilling Contractors, and Alberta Occupational Health and Safety.

200: Conducting the Inspection

205: Arrival at the Well Site

Contact with Operator's and Contractor's Representative

1. Whenever possible, the inspection should be conducted without prior notice given to the operator or contractor.
2. Upon arrival at the site, contact the Rig Manager (toolpusher) and the company representative.
 - If unavailable, locate the Driller.
3. Take time to get acquainted.
4. Explain the purpose of the visit.
5. Determine if hole conditions are safe to conduct a complete inspection.

Request by Operator or Contractor that BOPs NOT BE CHECKED

6. If the Rig Manager and/or the company representative request that the blowout preventers (BOPs) not be checked because of an operational problem, use discretion in deciding whether or not to proceed with the inspection
 - It is advisable to respect the wishes of the rig supervisors. An abbreviated inspection may, however, still be conducted.
 - Consult with your supervisor if there is concern about conducting a full inspection.

210: BOP System Requirements and Specifications

BOP Requirements

1. Refer to Appendix 1010 - Schedule 10 - Servicing Blowout Prevention Systems to determine the required type and pressure rating of the BOPs.

Tripping Small Diameter Tubing and Electrical Cables

2. An annular preventer must be installed whenever electrical cables, small diameter tubing control, or circulating strings are being tripped.
 - Notched rams are not a suitable replacement for an annular preventer.
 - See Section 235(13) for accumulator requirements.

Rod Jobs

3. When a rod string is being tripped a rod preventer must be installed on the tubing string.
 - The rod preventer permanently installed on the wellhead must not be used as the servicing preventer. A separate unit must be furnished.

- Tripping Small Diameter Tubing Inside Tubing**
4. The appropriate BOP requirements must be applied whenever small diameter tubing is being tripped inside tubing.
- Mechanical Ram Conversions**
5. Mechanically operated rams, that have been converted to hydraulically operated units, are acceptable provided they meet the operating requirements specified in this manual (see Section 235(12) and Section 240(5)).
- Annular Specifications – Class I Gas Wells**
6. A stripper type annular preventer may be used in lieu of a conventional annular preventer when servicing Class I Gas Wells.
- A stripper-type annular must have a pressure rating at least equal to the formation pressure.
 - A stripper-type annular is subject to the same accumulator requirements as imposed on a conventional annular.
- Breakdowns – Class I Gas Wells**
7. Class I Gas Wells must be fully blown down or killed prior to installing the BOP prevention equipment, unless a snubbing unit is in service.
- Tubing Strippers – Class 1 Gas Wells**
8. A tubing stripper must be installed either above or below the BOPs in a Class I Gas Well Blowout Prevention System.
- The stripper may be located below the preventer(s) provided it is an integral part of the wellhead.
 - The stripper may be either a manufactured or “poorboy” model.
 - No leakage should occur around the stripper during tripping operations. However, minimal leakage may occur when the collars enter the stripper.
- Tubing Plugs – Class I Gas Wells**
9. If a well is flowing, a tubing plug or other suitable shut-off device must be installed in the bottom joint of the tubing string to prevent flow from the tubing during tripping operations.
- Operations are to be suspended whenever a shut off device is not found in service.
- Lubricators**
10. After a well is perforated, a full lubricator must be installed when any form of wireline work is being performed.

BOP Quick Connectors

11. Quick connectors may be used to connect various flanged BOP equipment.
 - “Clamp Connections” (manufactured by Cameron) and Grayloc clamp connections (manufactured by Gray Tool Company) are acceptable.
 - Clamp-type connections can save many man hours when connections must be repeatedly made up and broken.

Double Drilling BOP Equipment

12. The double drilling of BOP equipment (BOP body, BOP flanges, adapter flanges, or spools) is acceptable; however, the following policies are recognized by industry:
 - Double studding the body of a BOP, to accept two sizes of API flanges (equipment which may have a lower pressure rating), does not result in a derating of the preventer.
 - Double drilling flanged BOP equipment, to accommodate connections to other API equipment (equipment which may have a lower pressure rating), results in a derating of the flange to the lower working pressure.
 - In many cases, derated flanges will be acceptable for the particular class of well being serviced. However, if a double drilled flange is to be used in an application requiring a higher pressure rating, the operator must provide evidence from either the manufacturer or a professional engineer (P.Eng.) that the flange is certified for the higher pressure (equipment identification must be established with the certification document).
 - If certification cannot be provided during the inspection, the operator must furnish the necessary evidence within a reasonable time-frame. If this cannot be done, a High Risk deficiency must be recorded on the rig inspection report.

The equipment must not be used for another servicing job until the matter is resolved.

Re-entries or Drilling Operations

13. Service rigs conducting re-entries or drilling below production or intermediate casing may be required to conform to a combination of drilling and servicing regulations (see section 23 of *Directive 036*).

Bleed-off and Kill Lines

15. Class I Gas Well BOP Systems require either one (75 mm) or two (50 mm) vent or flare lines through which gas can be discharged during servicing operations.
 - The line(s) must have a working pressure at least equal to or greater than the maximum reservoir pressure to be encountered.

- The line(s) must be connected to a valved spool below the preventer(s).
 - The line(s) must be securely tied down. Devices such as stakes (set at 10-m intervals), rubber tires filled with cement, pipeline weights, clamp and interconnecting cable mechanisms, or other properly designed devices, are acceptable.
 - Steel swivel joint connections may be used provided gas is not venting at the elbows or connections. If leakage is detected operations must be suspended until the problem is corrected.
- 16.* Class IIA Heavy Oil BOP Systems require one 50 mm kill line connected to the wellhead, spool or BOP port and extending a minimum of 15 m from the well during the servicing of a secondary recovery well.
- A bleed-off and kill line is not required during the servicing of a primary recovery well.
17. Class II and III BOP Systems require an additional spool and valve, or flanged BOP port and valve, for connecting bleed-off or kill lines.
- The spool or BOP port must be located below the lowest set of rams.
 - The spool and valve (including BOP port valve) must match the existing wellhead design. If flanged equipment is used on the wellhead, then the additional spool and valve must be flanged (flanges mated to back-welded threaded connections are only acceptable if the connection has been stress relieved. This generally requires shop fabrication).
 - Wellhead casing valves may be used for the bleed-off or kill line connection whenever a tubing hanger (dognut) is in place. However, once the BOP stack is installed, the spool or BOP port must be used for making the connection. The casing valves must be reserved for emergency purposes only.
 - A threaded BOP port is not acceptable for this connection because of potential thread damage which may occur through continuous make up and dismantling.

* A Primary Recovery Heavy Oil/Oil Sands Well, for the purpose of this manual, is defined as a well having a sandface reservoir pressure equal to or less than the hydrostatic pressure that would be exerted at the sandface if the well were filled with formation fluids. A Secondary Recovery Heavy Oil/Oil Sands Well (EOR), for the purpose of this manual, is defined as a well having a sandface reservoir pressure greater than that described above, by virtue of injection into the formation of fluid(s) other than water at ambient temperatures. This includes all wells that are a part of an active EOR project approved by the EUB and any offset wells within 1 km of an EOR well within the project.

18. Class II and III BOP Systems require both a bleed-off and kill line. The lines

- must be at least 50 mm nominal diameter.
- must have a working pressure equal to or greater than the production casing flange, or the formation pressure, whichever is the lesser.
- must be installed such that one line is connected to a spool or BOP port (see item 17) and the second line is connected to the tubing (or equipment is readily available to make this connection).
- must be either connected to the rig pump or rig tank.

Snubbing units and rigs completing rod jobs do not require bleed-off and kill lines or a pump and tank.

- may contain steel swivel joint connections.
- must be securely tied down. Devices such as stakes (set at 10 m intervals), rubber tires filled with cement, pipeline weights, clamp and interconnecting cable mechanisms, or other properly designed devices, are acceptable.

Flexible Hose in Bleed-off and Kill Lines

19. A flexible hose, without fire resistant sheathing, may be installed in the bleed-off and kill lines provided the hose has

- a working pressure equal to or greater than the production casing flange, or the formation pressure, whichever is the lesser.
- a nominal diameter of 50 mm (75 mm if single line used in Class I Gas Well BOP System).

Circulation Manifold

20. Class IIA BOP Systems do not require a circulation manifold during servicing operations. Return fluids must be contained. If a rig tank is used it must be located a minimum of 15 m from the well.

21. Class II and III BOP Systems require a manifold for the purpose of directing fluids to and from the well. The manifold must

- conform to the minimum design requirements set out in Schedule 10.
- have a working pressure equal to or greater than the production casing flange, or the formation pressure, whichever is the lesser.
- be valved to allow flow to be directed to the tubing, annulus, or rig tank.

- include a check valve to prevent back-flow to the rig pump.
- be equipped with a gauge and suitable fittings to accurately measure pump pressures.
- if equipped with an adjustable choke, have provisions made (upstream of the choke) for the installation of a gauge in order to maintain proper circulation pressures.
- be equipped with a pressure relief device, on the pump discharge, to prevent overpressuring of the circulation system (AOH&S regulation 202 requires the discharge line be secured).

Manifold Gauge

22. The manifold gauge must

- be installed or be readily accessible.
- have an operating range at least equal to the formation pressure.
- have readable increments not exceeding 500 kPa

Casing Gauge

23. A gauge and suitable fittings must be available to obtain the casing pressure during a well shut-in.

- The installation and operating conditions set out in item 22 above are also applicable to this gauge.

Degasser Requirements

24. A degasser is not required at the present time because of design and dispersion uncertainties. However, this matter is currently being studied and a degasser requirement is anticipated in the future.

Stabbing Valve

25. The rig must be equipped with a full opening stabbing valve, a closing wrench and the necessary cross-over subs to enable the make-up of the valve with tubing or any other pipe in the well.

26. The stabbing valve shall be

- kept readily accessible and operable.
- kept in the open position.

27. The stabbing valve does not have to be sized such that it can be stripped into the well.

28. The stabbing valve must be equipped with carrying handles or hanger caps if more than one person is required to handle it.

Floor and Remote Control Requirements

1. There must be both floor and remote controls for each BOP installed. The controls must be properly installed, correctly identified and show function operations (e.g. open-close, as well as accumulator system pressure).
2. The floor controls must be located near the Driller's position and be easily accessible. It is satisfactory for the controls to be located on the sub base, down a few stairs, or a few steps away. Use discretion.
3. The remote controls must be
 - located at least 7 m from the well for Classes I, II and IIA (at front of rig acceptable).
 - located at least 25 m from the well for Class III and be shielded or housed.
 - readily accessible.

Master Control Location

4. It is preferable, but not mandatory, that the main hydraulic controls (capable of closing and opening BOP's) be located at the remote panel and the auxiliary controls be located on the rig floor or near the Driller's station.

Check Valve Installation

5. A check valve must be installed between the accumulator recharge pump and the accumulator itself.
 - If the rig hydraulic system is used to recharge the accumulator, as in Classes I, II and IIA BOP Systems, the check valve must be located next to the accumulator and it must be visible.

Fire-proofing Hydraulic Lines

6. All non-steel hydraulic BOP control lines located within 7 m of the well, or located under the rig substructure, must be completely sheathed with fire resistant sleeving.

Manual Closing/Locking Handwheels

7. Check whether or not ram type preventers have automatic locking features. If they don't, then a closing/locking device must be installed or be readily accessible.

- Manual locking rams are easily identified as the manual locking shafts extend through the cylinder head permitting the installation of locking handwheels. Self-locking rams have enclosed ram shafts.
- A single handwheel is acceptable as the ram closing device.
- A ratchet and socket set is considered a suitable replacement for a handwheel.
- “Readily accessible” means the crew should be able to find the closing device without any searching whatsoever.

220: Crew Training and Certification

Conducting Crew BOP Drills

1. A crew BOP drill must be conducted during the inspection provided it is operationally prudent to do so.

Rig Supervisors' Involvement

2. The Rig Manager and/or the operator's representative should be requested to co-ordinate the blowout drill, following the procedures outlined in Appendix 1040.
 - The alert should be initiated by the Rig Manager or the operator's representative.
 - A horn is the required method of alerting the crew. A Low Risk deficiency exists if the rig does not have a horn, but the crew responds to an alternate alert. A High Risk deficiency exists if the horn is not operable and the crew does not respond to any form of alternate alert.

Drill Requirements

3. The drill conducted should determine the crew's ability to detect a well kick and perform a shut-in for the operation in progress at the time of the inspection.
4. The crew should be capable of applying well control procedures for four situations: when drilling or working with a kelly or power swivel, while tripping, when pipe or tubing is out of the hole, while tripping sucker rods.

Inspector's Role

5. The inspector's role throughout the drill should be that of an observer unless it is apparent that the servicing supervisors need some assistance in establishing the format of the drill. The inspector may also question the crew about specific well control procedures.

Crew Assessment and Procedures Forms

6. Use the Crew Training Assessment Form and the Crew Procedures Form(s) when observing drills.
 - The Crew Training Assessment Form (Appendix 1035) only serves as a guide and is not to be left at the rig. It may be appropriate to retain the form in the office files if crew training is found deficient.
 - The Crew Procedures Charts (Appendix 1040) only serve as guides during the inspection.

Hands-on Drill Not Possible

7. If adverse hole conditions will not permit a “hands-on” drill, have the Rig Manager and/or operator's representative conduct a verbal drill on the lease.
8. If the crew is not properly trained operations must be suspended until additional training is provided. The necessary training should be provided by the on site supervisors; however, the inspector may wish to offer some assistance.

Recording Blowout Drills

9. Check the tour sheets to ensure that a blowout drill is conducted by each crew a minimum of once every 7 calendar days.

Blowout Prevention Certificate

10. At minimum, the driller must possess a valid well service control certificate issued by Energy Safety Canada (ESC), the International Well Control Forum (IWCF), the International Association of Drilling Contractors (IADC), or an equivalent organization. However, the duty holder would have to submit a gap analysis to the AER (welloperations@acr.ca) for a determination of whether the training is equivalent. It is recommended that the licensee's well site representative and rig manager also obtain the certificate.
 - The inspector should request to see the Driller's certificate to ensure that he does in fact have one and secondly, to ensure that it hasn't expired.
 - If the Driller claims to have a valid certificate, but is unable to produce it during the inspection, the inspector must take the necessary follow-up action to substantiate the Driller's claim (this may be done either during or immediately after the inspection).
 - It is a High Risk deficiency if the Driller has never held a certificate and the rig must be shut down until such time as a qualified Driller takes over operations.
 - A High Risk deficiency exists if the Driller's certificate has expired. In such cases, a recommendation should be made that his/her certificate be renewed.(comment on inspection report if Driller has registered to acquire certification).

225: BOP Mechanical Test

BOP, Accumulator, and Recharge Pump Check

Class I BOP System – Gas Wells*

1. Have crew remove slips and wiper rubber, if in use.
2. If no tubing is in the well, have crew run in joint of tubing in order to check the annular and tubing stripper.
3. Have crew shut down accumulator recharge pump.
 - This may be the rig's hydraulic pump (if so, use emergency motor kill).
4. Observe and record accumulator operating pressure.
5. If rig hydraulic pump is used to charge accumulator and pump is a single-stage unit, have crew operate power tongs to determine if accumulator pressure decreases.
 - If pressure remains the same, the check valve on the accumulator recharge pump is holding pressure on the accumulator.
 - If pressure bleeds off, the rig should be shut down until pressure can be maintained (check valve may need replacing, etc.).
6. Have crew close annular (periodically use remote controls).
 - Closing time for annular is 60 seconds.
 - Visual check of annular element may not be possible if tubing stripper is positioned above annular (element may be viewed if stripper is integral part of wellhead - see Section 210, item 8).
7. Observe and record accumulator pressure.
 - If an annular is being checked this pressure is only an indication that the accumulator is functioning and sizing calculations must be performed. A High Risk deficiency automatically exists whenever 8400 kPa or less remains on the system after completing a mechanical test.
 - **Calculations are necessary because the annular preventer is checked with pipe in the well. Calculations will indicate if the accumulator has additional usable fluid available (at a minimum pressure of 8400 kPa) to close the annular on open hole. If it doesn't, a High Risk deficiency exists.**

* The following procedure is based on the assumption that an annular preventer is in service on a Class I Gas Well. However, if ram preventers are employed, the procedures outlined for a Class II BOP System should be followed.

8. Have crew start up accumulator pump.
 - Accumulator must recharge to its original operating pressure within 5 minutes at idle speed (see either item 9 or 10 in Section 235 if this is not achieved).
9. Have crew open annular.
10. Operate the BOP again from the opposite set of controls to ensure proper function from both sets of controls (floor and remote).

BOP, Accumulator and Recharge Pump Check

1. Have crew remove slips and wiper rubber, if in use.

Class II or IIA (Heavy Oil Wells) BOP System *

2. Have crew shut down accumulator recharge pump.
 - This may be the rig's hydraulic pump (if so, use emergency motor kill).
3. Observe and record accumulator operating pressure.
4. If rig hydraulic pump is used to charge accumulator and pump is a single stage unit, have crew operate power tongs to determine if accumulator pressure decreases.
 - If pressure remains the same, the check valve on the accumulator recharge pump is holding pressure on the accumulator.
 - If pressure bleeds off, the rig should be shut down until pressure can be maintained (check valve may need replacing, etc.)
5. ** Have crew close pipe rams.
 - Closing time for rams is 30 seconds.
 - Visually check condition of ram rubbers and size of rams.
6. ** Have crew open pipe rams.

* The following procedure is based on the assumption that tubing is in the hole; therefore, the blind rams cannot be included in the accumulator sizing check. The pipe rams are closed and opened, in steps 5 and 6, in order to compensate for the inability to close the blind rams (fluid volumes required to close and open pipe and blind ram preventers are approximately the same).

** If tubing is not in the hole, the blind rams should be used. The pipe rams should then be checked after step 8 (have rig crew run in joint of tubing before closing pipe rams).

7. Observe and record accumulator pressure.
 - 8400 kPa is the minimum pressure acceptable for ram preventers (recommended by BOP manufacturers). Accumulator sizing calculations do not have to be performed if this pressure is maintained.
 - A High Risk deficiency exists whenever less than 8400 kPa remains on the system.
8. Have crew start up accumulator recharge pump.
 - Accumulator must recharge to its original operating pressure within 5 minutes (see either item 9 or 10 in Section 235 if this is not achieved).
9. Operate the BOP again from the opposite set of controls to ensure proper function from both sets of controls (floor and remote).

Reminder: Class III BOP requirements and test procedures must be followed if a Class III BOP stack is used on a Class II well (see Section 235(13) for exception).

Redundant Servicing Equipment

1. Whenever redundant servicing equipment is in place it must remain functional at all times unless equipment is locked out.
 - Deficiencies noted with redundant equipment are to be recorded as outlined in section 1050 on the inspection report.
2. All redundant equipment which is not in service must be “locked out” in an appropriate fashion (e.g. unplug, remove handles, disconnect lines, use locks and the like).
 - Inspectors must ensure that locked-out equipment is completely inoperable.
3. Should the equipment be connected, it must be fully functional, operate correctly, be identified and included in all accumulator and back-up nitrogen system volume calculations. If found deficient, the items are to be corrected as with any other deficiency on the minimum equipment.

**BOP, Accumulator and Recharge
Pump Check
Class III BOP System***

1. Have crew remove slips and wiper rubber, if in use.
2. Have crew shut off accumulator recharge pump.
 - Recharge pump must be independent from rig's hydraulic system.
3. Observe and record accumulator operating pressure.
4. Have crew close pipe rams.
 - Closing time for rams is 30 seconds.
 - Visually check condition of ram rubbers and size of rams.
5. Have crew open pipe rams.
6. Have crew close annular preventer (periodically use remote controls).
 - Closing time for annular is 60 seconds.
 - Visually check condition of annular element.
7. Observe and record accumulator pressure.
 - This pressure is only an indication that the accumulator is functioning and sizing calculations must be performed. A High Risk deficiency automatically exists whenever 8400 kPa or less remains on the system after completing a mechanical test.

Calculations are necessary because the annular preventer is checked with pipe in the well. Calculations will indicate if the accumulator has additional usable fluid available (at a minimum pressure of 8400 kPa) to close the annular on open hole. If it doesn't, a High Risk deficiency exists.

8. Have crew start up accumulator recharge pump.
 - Accumulator must recharge within 5 minutes (see either item 9 or 10 in Section 235 if this is not achieved).
9. Have crew open annular preventer.

* The following procedure is based on the assumption that tubing is in the hole; therefore, the blind rams cannot be included in the accumulator sizing check. The pipe rams are closed and opened, in steps 4 and 5, in order to compensate for the inability to close the blind rams (fluid volumes required to close and open pipe and blind ram preventers are approximately the same).

This procedure should be followed even if tubing is not in the hole. Always ensure that a joint of tubing is run in the well before conducting any tests on the annular and pipe rams.

10. Have crew remove joint of tubing, if one has been run in order to perform tests.
11. Have crew close blind rams (only if no pipe in well).
 - Periodically use remote controls.
 - Visually check condition of ram rubbers.
12. Have crew open blind rams (if step 11 performed).
13. Operate the BOP again from the opposite set of controls to ensure proper function from both sets of controls (floor and remote).

230: Air Shut-offs/Diesel and Gasoline Engine Spacing

Reason for Shut-offs

The purpose of air shut-offs is to prevent diesel motors from running uncontrolled in the event of a natural gas blow from the well. Since diesels are compression ignition engines, fuel shut offs will be ineffective in stopping the engine if it is drawing a combustible air gas mixture into its air intake.

Shut-off Requirements

1. Ensure that any diesel engine within 25 m (75 feet) of a well is equipped with
 - an adequate air intake shut-off valve equipped with a remote control readily accessible from the Driller's position, or
 - a system for injecting an inert gas into the engine's cylinders, equipped with a remote control, or
 - a suitable duct so that air for the engine is obtained at least 25 m (75 feet) from the well.

Confirming Shut-off Test with Well-site Supervisors

2. Before conducting a mechanical test of the air intake shut-offs, consult with the Rig Manager and/or operator's representative as to possible problems (hole problems, inability to restart motor, etc.).

Disengaging Clutches

3. When conducting the test, ensure that the engines are idling and the clutches are disengaged so that all engines will have to stop independently.
4. Request that the test be conducted by having the air shut-off control activated.

Individual Motor Tests

5. The motors may be tested individually by holding the air shut-offs open.
 - This may alleviate possible problems of engines failing to restart.
 - It is a good check to ensure that fuel shut-offs are not being operated in place of the air shut-offs.

Shut-off Test Results

6. The motors will power down and stop rapidly. The motors must stop for the test to be successful - engine lugging is not acceptable.

Spacing for Vehicles Without Air Shut-offs

7. Vehicles (diesel or gasoline) are not allowed within 25 m (75 feet) of a well during well servicing. However, vehicles essential to operations may operate within this distance provided the well-site supervisors first assess the on-site safety.
 - This policy applies in instances where a vehicle may be unloading supplies such as tubular goods.
 - It does not apply where a vehicle may be performing an operation on the well (e.g. pressure truck).

Rig Pump (Engine) Spacing and Requirements

8. A rig pump (diesel engine) must be located not closer than 7 m (25 feet) to a rig tank (see Schedule 11) and should be spotted according to the direction of the prevailing wind. The engine must also be equipped with
 - an adequate air intake shut-off valve, or
 - a system for injecting an inert gas into the engine's cylinders.

Bailing Tank (Heavy Oil Only) Spacing Exception

9. Bailing operations may be conducted to an open tank. The tank may be adjacent to the well but must be removed as soon as bailing operations are complete.

Tank Truck Spacing and Requirements

10. Diesel tank trucks transferring fluids either to or from the rig tank must also adhere to the same requirements outlined in item 8 above.

Spacing (Engines) near Rig Tank

11. Diesel or gasoline engines not associated with the transfer of rig tank fluids must be located not closer than 25 m (75 feet) to the rig tank, whenever the wellbore is open to the tank.

Handling Spacing Problems

12. Spacing problems related to items 7, 9, and 10 above do not constitute an unsatisfactory rig inspection. A comment that a problem existed and that it was corrected should only be made on the inspection report.

Engine Exhausts

13. An exhaust pipe from an internal combustion engine located within 25 m (75 feet) of any well must
 - be constructed to prevent any emergence of flame along its length or at its end,
 - end not closer than 6 m (20 feet) to the vertical centreline of the well, and must be directed away from the well.

Spacing exemptions may be granted by Area office staff provided the operator discusses its spacing needs with the appropriate Area Office before commencing operations.

235: Accumulator Sizing and Operating Policies

Accumulator Requirements

1. The accumulator must have sufficient usable fluid available, at a minimum pressure of 8400 kPa, to close all BOPs.

When to Complete Sizing Calculations

2. **Accumulator sizing calculations must be completed during the initial inspection of a rig when an annular preventer is in service.**

The above policy applies even if an actual mechanical test of the BOP equipment cannot be completed according to the procedures outlined in Section 225.

- See item 5 of this section or Appendix 1025 for sizing methods.

Recording Accumulator Specifications

3. Determine and record the accumulator system's make, number of bottles, capacity, design pressure, and operating pressure (upstream of any regulators).
 - Accumulator Specifications should be available at each rig and this includes Specifications for “homemade” models. Operators and/or contractors should be encouraged to complete a BOP Data sheet similar to Drawing No. 1 on page 5.
 - Operators of “homemade” models must affix a tag to their units indicating the manufacturer, working pressure, and capacity.

Reminder: Subtract one US gal from nominal size of each accumulator bottle to account for displacement of bladder or float assembly (see Table No. 1 on page 6 for accumulator specifications).

Reminder: Accumulators are sized in US gals. Use the following for conversions:

$$\text{US gals} \times 3.7854 = \text{litres}$$

Determining Precharge Pressure

4. If well conditions allow, and it is safe to do so, have the Manager check the precharge pressure on each accumulator bottle. Record pressures.
 - A gauge and the necessary fittings must be readily available to determine the pressures.
 - Another method of determining precharge is available if the well-site supervisors are concerned about the “down time” necessary for determining individual pressures or if a proper gauge and fittings are not available. However, this method will only indicate the lowest precharge in service and it also has a number of other shortcomings which could create problems for less experienced inspectors. It should only be used as a last resort for calculation purposes.

METHOD:

- A. Shut down recharge pump.
- B. Depressure accumulator.
- C. Restart pump.
- D. Observe first pressure* obtained on accumulator gauge—this is the lowest precharge pressure available.

* It should only take a few seconds to obtain this pressure.

Sizing Methods

5. Two methods for calculating accumulator sizes are provided in the manual.
 - Method 1, shown in item 6, is the preferable method to use during inspections because of its simplicity.
 - The “Alternate Method”, shown in Appendix 1025, requires more detailed calculations.
 - Drawing No. 2 (page 7), in Method 1, is derived from the equations shown in Appendix 1025.

Sizing Calculations (Method 1)

6. Complete usable fluid volume calculations, using Drawing No. 2, and the following procedures:
 - Using pressures obtained in items 3 and 4 and Drawing No. 2, follow accumulator operating pressure slope on drawing (go beyond apex for precharge less than 8400 kPa) until it intersects with the appropriate vertical precharge pressure line.
 - Read drawing's left vertical axis to determine the percentage of total accumulator capacity which is considered usable at the current operating pressures.
 - Calculate usable fluid using percentage determined.

Usable Fluid = Per cent x Acc Cap

- Determine and total the required closing volume for each BOP component (see Appendix 1055) and compare it with volume of usable fluid calculated earlier.
 - The accumulator is adequately sized if the usable fluid volume is equal to or greater than the fluid volume required to close all BOP components.
7. Remember to include “redundant equipment” in usable fluid volume requirement calculations.
(See section 225(3)).

EXAMPLE SIZING CALCULATION

Rig has 76-litre accumulator, operating at 14-MPa and 7-MPa precharge pressure

Per cent usable fluid available at current operating pressures - 33.5%

CALCULATED USABLE FLUID $\frac{33.5}{100} \times 76 \text{ litres} = 25.5 \text{ litres}$

Rig Has 21-MPa BOP Stack Consisting of:

152.4-mm Shaffer Spherical BOP - closing vol req'd	17.3 litres
152.4-mm Shaffer LWP Tubing Rams - closing vol req'd	2.1 litres
152.4-mm Shaffer LWP Blind Rams - closing vol req'd	<u>2.1</u> <u>litres</u>
TOTAL CLOSING VOLUME REQUIRED	21.5 litres

- The accumulator is adequately sized since the usable fluid volume available exceeds the closing volume required.

DRAWING No.1
EXAMPLE ONLY

DRILLING OR SERVICING BOP DATA

CONTRACTOR _____ RIG No. _____ STACK: PRESSURE RATING _____ kPa
 SIZE _____ mm
 NACE TRIM _____
 NACE CERTIFIED _____

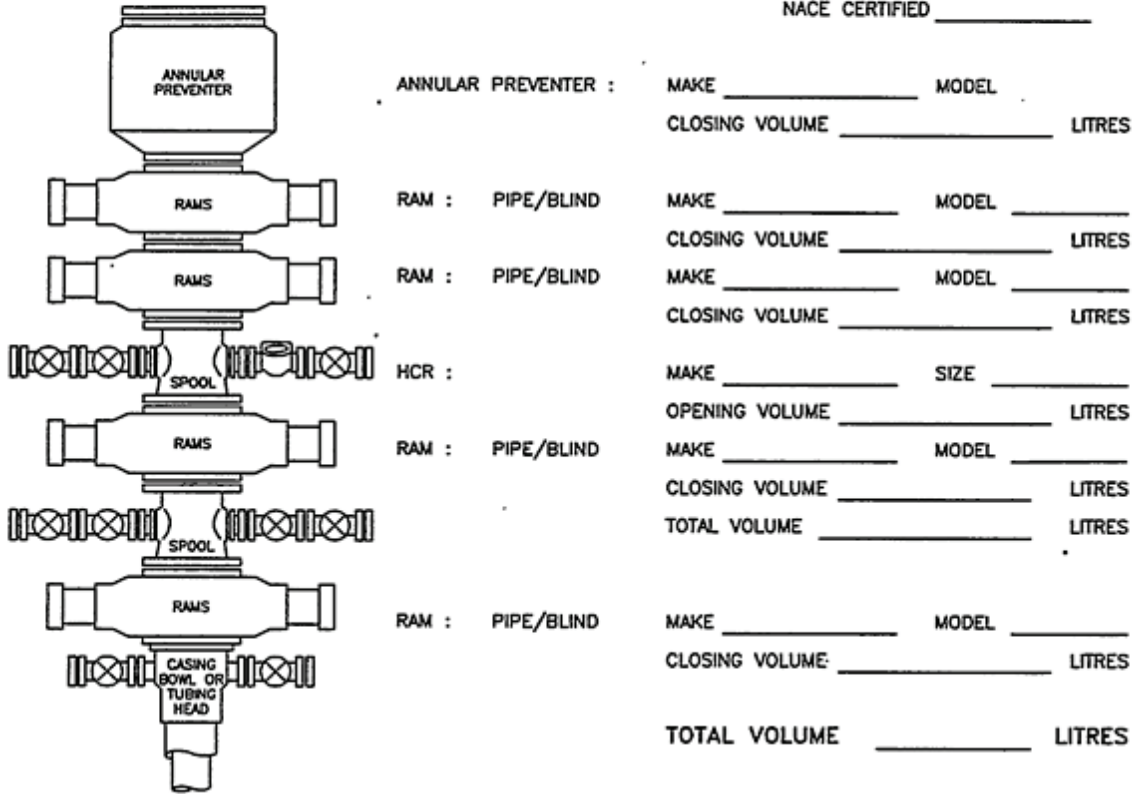

INSTRUCTIONS

1. CROSS OUT NON-APPLICABLE EQUIPMENT (PREVENTERS, SPOOLS, VALVES)
2. MARK RAMS AS PIPE OR BLIND
3. MEASURE BOTTLE HEIGHT (NITROGEN BACK-UP) FROM TOP OF VALVE

CLOSING UNIT DATA

MAKE _____ MODEL No. _____
 DESIGNED PRESSURE RATING _____ kPa
 ACCUMULATOR : No. BOTTLES _____ TOTAL VOLUME _____ LITRES
 NITROGEN (BACK-UP) : No. BOTTLES _____ BOTTLE HEIGHT _____ m
 TOTAL CAPACITY _____ LITRES

TABLE 1 ACCUMULATOR SPECIFICATIONS
VOLUME PER NO. OF ACCUMULATOR BOTTLES
 CYLINDRICAL

						SPHERICAL			
5* gal Bottles	(4)** Litres	10 gal Bottles	(9) Litres	11 gal Bottles	(10) Litres	15 gal Bottles	(14) Litres	80 gal Bottles	(79) Litres
1	15.1	1	34.1	1	37.9	1	53.0	1	299.0
2	30.2	2	68.2	2	75.8	2	106.0	2	598.1
3	45.3	3	102.3	3	113.7	3	159.0	3	897.1
4	60.4	4	136.4	4	151.6	4	212.0	4	1 196.2
5	170.5	5	189.5	5	265.0				
6	204.6	6	227.4	6	318.0				
7	238.7	7	265.3	7	371.0				
8	272.8	8	303.2	8	424.0				
9	306.9	9	341.1	9	477.0				
10	341.0	10	379.0	10	530.0				
11	583.0								

* nominal volume

** actual volume

COMMON ACCUMULATOR SUPPLIERS AND SIZES

Koomey: Bottle availability 5 gal workover (4) Greer (manufacturer)
 10 gal (9)
 11 gal (10)
 15 gal (14)
 80 gal Spherical (79)

e.g. Model #TA112-15BF3 T series, 112 gal - 15 gal, Buoyant Float, 3000 psi

Wagner: Same bottles as Koomey

e.g. Model #10-060-3BB 10 hp - 60 gal - 3000 psi, Buoyant Bladder

Valvcon: Bottle availability 15 gal standard (14) Valvcon (manufacturer)
 80 gal spherical (79)
 5 gal & 10 gal non-standard

e.g. Model #90-E10GD-1B60 90 gal electric, 10 hp pump style, 1 pump, ratio 60:1

NL Shaffer: Bottle availability 11 gal (10) Greer (manufacturer)

Cameron: Bottle availability 20 gal standard (19) Payne (manufacturer)
 27, 35, 50, 80 gal
 (available)

DRAWING NO.2

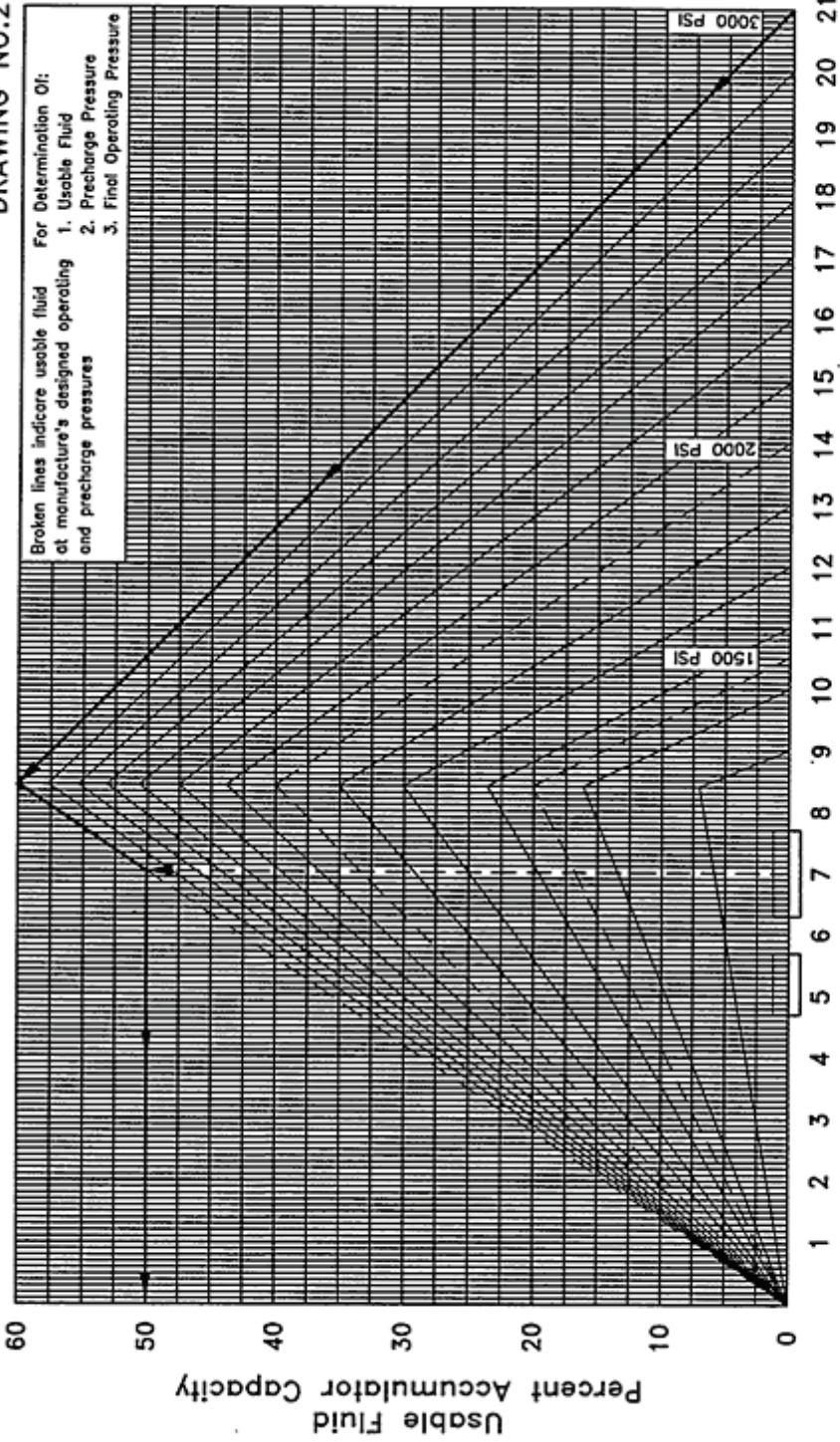

ACCUMULATOR VOLUME/PRESSURE ABOVE 8400 kPa

Drawing Credit: K. Caldwell
Dome Petroleum LTD.

Sizing Rechecks

7. Once an initial accumulator sizing check has been completed for Class I and Class III BOP systems (where annular is in service) it is not necessary to complete sizing calculations during each subsequent rig inspection—provided the accumulator's operating parameters and BOP stack remain the same.

Precharge Requirements

8. Full precharge is not required for an accumulator to meet the requirements for Class I, II, IIA or III BOP systems.
 - For Classes I, II & IIA, where only ram preventers are installed, the accumulator is considered adequate, regardless of its precharge pressure, if after closing and opening the preventer the pressure remaining on the system is at least 8400 kPa.
 - For Classes I and III, where an annular preventer is installed, the accumulator is considered adequate, regardless of its precharge pressure, if sufficient usable fluid is available to close all the preventers (annular on open hole) and retain a minimum accumulator pressure of 8400 kPa. Sizing calculations must be performed.

Manufacturers' recommended precharge:

5250 kPa (± 10%) for 10 500 kPa system

7000 kPa (± 10%) for 14 000 kPa system

7000 kPa (± 10%) for 21 000 kPa system

Recharge Pump Problems

9. If the accumulator recharge pump fails to recharge the accumulator to its original operating pressure when an annular preventer is in service, a complete function test of the BOP components and sizing calculations must be completed to reconfirm that adequate usable fluid is available while operating at the lower accumulator pressure.
10. If the accumulator pump fails to recharge the accumulator to its original operating pressure when only ram preventers are in service, a complete function test of the BOP components must be completed to reconfirm that 8400 kPa will remain on the system while operating at the lower accumulator pressure.

Low-pressure Alarm System

11. Board inspectors should recommend that a low pressure alarm system be installed in instances where decreasing accumulator pressures have gone undetected by a particular operator and/or contractor.
 - This option should be considered the second time a problem is noted.

- Electronic alarms, using either a warning light or horn, can be installed without difficulty.
- The alarm setting should be integrated with the accumulator's operating pressure.

Mechanical Ram Conversions

12. Manual ram preventers, converted to hydraulic motor drives, require a minimum of 7.6 litres (2 US gal) usable fluid to close each set of 152.4 mm rams. The inspector must ensure that the accumulator is sized accordingly.

Accumulator Requirements when Annular Installed for Tripping Small Diameter Tubing and Electric Cables

13. Even though the annular preventer would normally be the only BOP component activated during the tripping of small diameter tubing and electrical cables, the rig's accumulator system must still have sufficient usable fluid available, at a minimum pressure of 8400 kPa, to close all connected preventers.
 - Wells requiring a Class I BOP stack will only require an annular preventer.
 - When a Class II well requires an annular preventer, it is acceptable for contractors to temporarily disconnect the pipe rams (if installed) from the rig's accumulator system and utilize the rams' controls to function the annular.
 - No variations are permitted for wells requiring a Class III BOP stack.
 - A remote accumulator system will only be necessary when a Class III BOP stack is required.

Accumulator Reservoir Venting

14. It is recommended that an accumulator reservoir which is enclosed in a building must have its vent installed in such a manner that venting takes place outside the building. (Do not mark this item unsatisfactory on the rig inspection form.)

240: Back-up Nitrogen Supply

Nitrogen Requirements

1. Sufficient usable* nitrogen must be available, at a minimum pressure of 8400 kPa, to fully close all BOPs (including “redundant equipment” see section 225).

The nitrogen supply must be tied into the system at a point which will allow the N₂ to function the BOPs and not be lost by venting or displacement into the accumulator bottles. (see CAODC technical bulletin T92-2) and Appendix 1030, to determine if the rig system is properly configured.

* Usable is defined as the equivalent litres of stored nitrogen at a minimum pressure of 8400 kPa.

Recording Nitrogen Particulars

2. Determine and record the number of nitrogen bottles in service. Determine if the bottles are in cross flow (on a common line tied into the system). If they can be equalized when both bottles are open, then the pressure must be averaged and the usable fluid volume calculated using an average of all bottles. If the bottles are independent of each other by means of a check valve installed on each bottle (if open pressure on both bottles cannot be equalized) then the pressure in each bottle can be used individually to calculate the usable fluid equivalent. To calculate, see examples Section 240 or Appendix 1030.

Nitrogen Calculation (Method 1)

3. After completing usable volume calculations, use the following procedures:

Plot the pressure from the bottles in service either combined average or independently as determined from item 2 above, on a vertical axis and draw a horizontal line across the appropriate bottle size, then plot perpendicular line down to horizontal axis. Read equivalent litres of usable nitrogen. Total the fluid volume determined.

Multiply the usable nitrogen volume by the number of bottles in service to determine the total usable volume available.

Determine and total the fluid volume required to close all preventers (see Appendix 1055) and compare this volume with the volume of usable nitrogen calculated earlier.

The back-up nitrogen supply is adequate if its calculated volume is equal to or greater than the fluid volume required to activate the BOP components.

Manual Ram Conversions

5. Manual ram preventers converted to hydraulic motor drives also require a back up nitrogen supply (field tests indicate nitrogen will operate hydraulic motors).

Hydraulic motor drives require a minimum of 7.6 litres (2 US gal) usable fluid to close each set of 152.4 mm rams. Therefore, an equivalent volume of nitrogen must be available.

EXAMPLE NITROGEN CALCULATION – For “Averaged” bottles system.

Rig has two 42-litre nitrogen bottles available:

Bottle 1 @ 17.5 MPa - Bottle 2 @ 14.0 MPa

Average bottle pressure $\frac{17.5 \text{ MPa} + 14.0 \text{ MPa}}{2 \text{ bottles}} = 15.75 \text{ MPa}$ * - use average or independent pressures see Section 240(2).

Usable fluid (per bottle) from drawing 37.0 litres

TOTAL USABLE FLUID 2 X 37.0 LITRES 74.0 litres

Rig has 21-MPa BOP stack consisting of:

152.4-mm Shaffer Spherical BOP - closing vol req'd 17.3 litres

152.4-mm Shaffer LWP Pipe Rams - closing vol req'd 2.1 litres

152.4-mm Shaffer LWP Blind Rams - closing vol req'd 2.1 litres

TOTAL CLOSING VOLUME REQUIRED 21.5 litres

- Nitrogen volume is acceptable since 74.0 litres are available when only 21.5 litres are required to close BOPs.

Example Nitrogen calculation for “individual bottle” pressure - see drawing No. 2.
 Rig has two 42-litre nitrogen bottles available: Tied in but independent isolation by check valve.

Bottle 1 @ 16.5 mpa useable fluid from drawing	41.0 litres
Bottle 2 @ 14.7 mpa useable fluid from drawing	<u>31.5</u> litres
TOTAL USEABLE FLUID	72.5 litres

Rig has 21 mpa BOP stack - components to be considered:*

254 mm Hydril GK-900 annual BOP - closing vol. req'd	28.1 litres
254 mm Hydril MPL Pipe ram - closing vol. req'd	12.5 litres
101.6 mm Cameron HCR Hydraulic valve - opening vol. req'd	<u>2.3</u> litres
TOTAL CLOSING/OPENING VOLUME REQUIRED	42.9 litres

Nitrogen volume is acceptable since 72.5 litres are available when only 42.9 litres are required to activate BOP components.

* If two sets of runs are required or redundant equipment is in service (not locked out) the closing volume for each component must be included in the calculations.

Drawing No. 1

N₂ Bottle Configuration

Common Line “crossflow” equalized system

- Use average pressure from all bottles.

Drawing No. 2

N₂ Bottle Configuration

Independent bottles isolated by check valve

- Use individual pressure from each bottle.

Figure 1
N2 BOTTLE CONFIGURATION

Common line "Crossflow" equalized system
- use average pressure from all bottles.

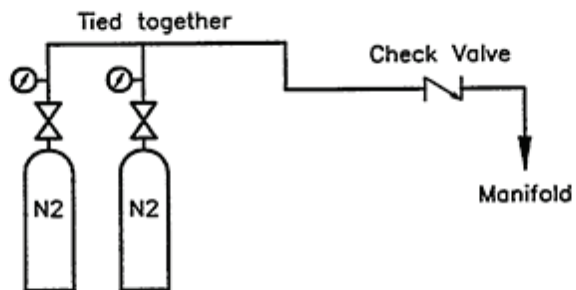
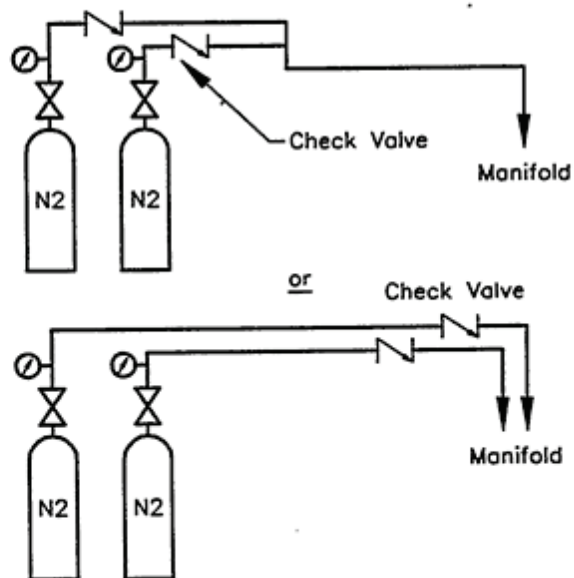
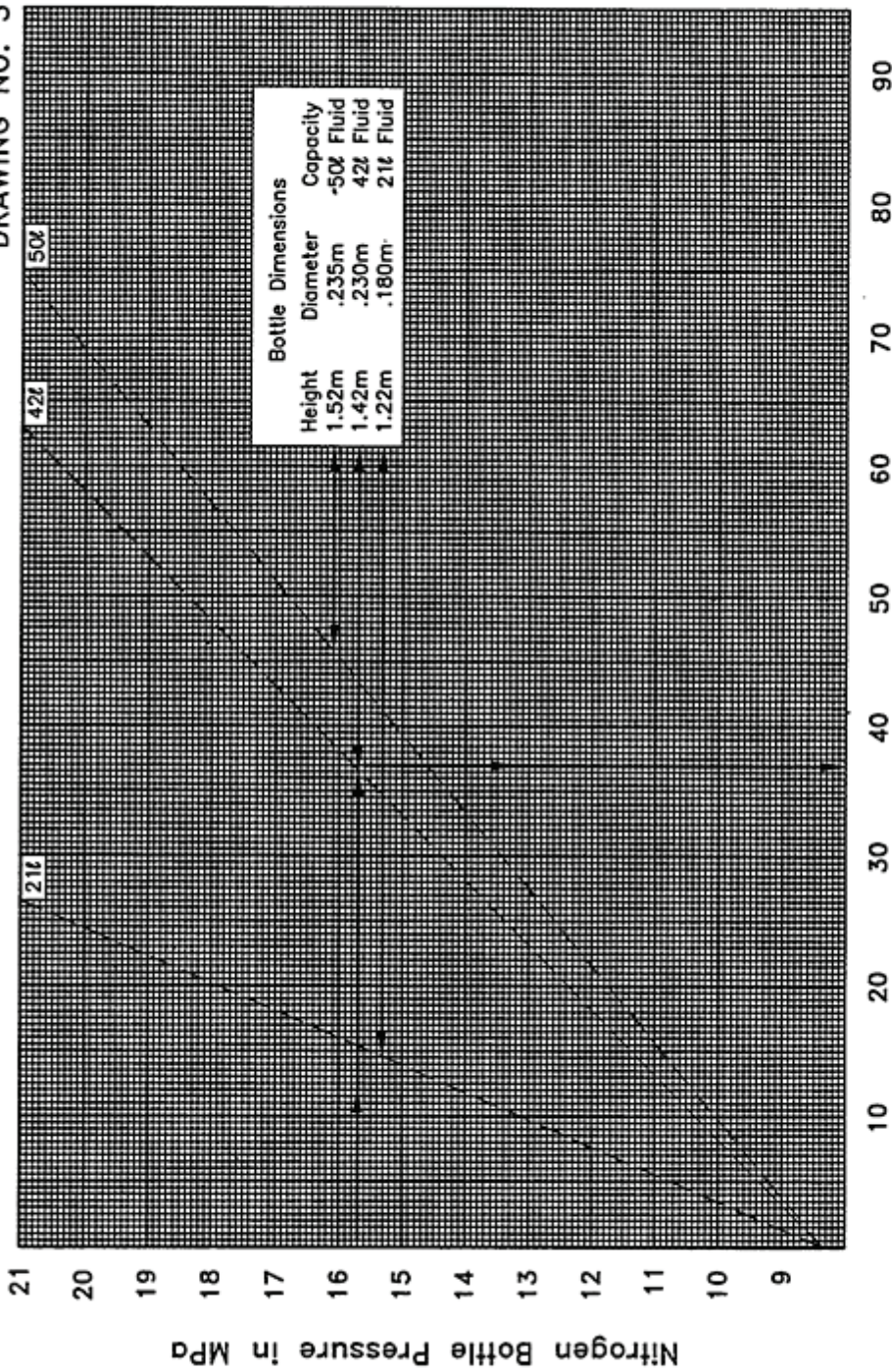

Figure 2
N2 BOTTLE CONFIGURATION

Independent bottles isolated by check valve
- use individual pressure from each bottle.



DRAWING NO. 3



Equivalent Litres of Usable Nitrogen
 Nitrogen Bottle Usable Volume Graph Above 8400 kPa

Drawing Credit: K. Caldwell
 Dome Petroleum LTD.

245: Winterizing BOP Equipment

BOP Stack and Accumulator Heating

1. The policies outlined in the following tables must be applied during cold weather operations.

The ambient temperatures in the tables are a guide for initiating a heating requirement check. The BOP body temperature is the determining factor for enforcement action.

ANNULAR ELEMENT HEATING REQUIREMENTS			
AMBIENT TEMP (°C)	BOP CONDITION	ELEMENT REQUIRED	SUPPLEMENTARY HEAT
ABOVE -10°C	ICE FREE	ANY ELEMENT	NONE
BELOW -10°C	ICE FREE	ANY ELEMENT	SUFFICIENT HEAT REQUIRED TO MAINTAIN BOP BODY TEMP ABOVE -10°C

RAM ELEMENT HEATING REQUIREMENTS			
AMBIENT TEMP (°C)	BOP CONDITION	ELEMENT REQUIRED	SUPPLEMENTARY HEAT
ABOVE -10°C	ICE FREE	ANY ELEMENT	NONE
BELOW -10°C TO -25°C	ICE FREE	IDENTIFIABLE LOW TEMP ELEMENT	* NONE
BELOW -25°C	ICE FREE	IDENTIFIABLE LOW TEMP ELEMENT	* SUFFICIENT HEAT REQUIRED TO MAINTAIN BOP BODY TEMP ABOVE -25°C

* A standard element may be used at any ambient temp provided sufficient heat is applied to maintain the BOP body temp above -10°C.

ACCUMULATOR REQUIREMENTS DURING COLD WEATHER OPERATIONS
THE ACCUMULATOR MAY NOT REQUIRE HEAT; HOWEVER, IT MUST REMAIN FUNCTIONAL AT ANY AMBIENT TEMPERATURE

Determining BOP Body Temperature (Surface Thermometer)

2. A surface thermometer, which may be affixed to the BOP stack, should be used for determining BOP body temperatures.

Winterizing Bleed off

3. The bleed-off line, kill line, and manifold require winterizing
 - These components may be drained, filled with a freezing depressant fluid (e.g. glycol), or be blown out with air.
 - Ask the rig supervisors what method was used to winterize these systems.

Use of Diesel Fuel

4. The use of diesel fuel in the bleed-off and kill system should be discouraged because diesel
 - does not serve as an absorbent as does glycol.
 - simply displaces water from the system (total displacement may not always be successful).
 - is flammable (flash point approximately 48-59 degrees C).
 - may not be compatible with valve gaskets and/or packing.
 - when cooled, may become cloudy, “gel”, as fine wax crystals precipitate. Also, dissolved water may form very fine ice crystals (summer fuel -9/-15, winter fuel -41/-42 degrees C). Therefore, wax (and ice) could hamper operation of the system.

Use of Glycol

5. Operators and contractors should be reminded to follow the manufacturer's mixing requirements when using glycol to winterize the bleed-off and kill system. An improper mixture, even from the standpoint of adding too much glycol, can create a problem during cold temperatures.

250: Spacing Regulations

Well to Flame-type Equipment

1. No flame-type equipment shall be placed or operated within 25 m (75 feet) of a well, oil storage tank, or other source of ignitable vapour (except water injection wells).
 - Flame-type equipment is any fired heating equipment using an open flame. It includes a space heater, torch, heated process vessel, boiler, electric arc or open flame welder.
 - Grinders, appliances must not be used within 25 m without shutting in the wellbore first.

Welding

2. Special circumstances may necessitate welding within 25 m (75 feet) of a well. Strict safety procedures must be adhered to, which include closing the applicable BOPs.

Well to End of Flare Line

3. The flare pit and the termination of all flare lines shall be at least 50 m (150 feet) from a well (see Section 320(2) for method of handling deficiency).
4. The flare pit shall
 - be excavated to a depth of not less than 2 m.
 - have side and back walls rising not less than 2 m above ground level.
 - be constructed to resist the erosion of a high pressure flow of gas or liquid.
 - be shaped to contain all liquids.

Wellsite Waste Management

5. Waste materials must be disposed of in accordance with Appendix 1100.

Well to Crude Oil Storage Tank

6. No oil storage tank shall be located within 50 m (150 feet) of a well, unless approved by an EUB representative (see Section 320(2) for method of handling deficiency).

Spacing exemptions may be granted by Area Office staff provided the operator discusses its spacing needs with the appropriate Area Office before commencing operations.

255: Handling Sour Effluent

Operations Not Permitted

1. Circulating, swabbing, or flowing sour effluent (regardless of H₂S concentration) to an open rig tank or flare pit is discouraged. If a potential hazard exists for on site personnel, or if an odour problem could be created for local residents, then proper containment equipment must be installed before operations begin.
 - Operators are encouraged to consult with area office staff if they have concerns regarding equipment needs for specific wells or areas.

Proper Handling Methods

2. Sour effluent must be handled by one of the following methods:
 - By installing proper separation equipment, whereby the sour liquids are directed to a storage tank equipped with a vapour gathering system (VGS). Gas discharged from the separator and VGS must not be vented to atmosphere.
 - Producing the effluent to an existing separation facility which is properly equipped to handle sour products (flow line already in place).

Inspector's Involvement

1. Although field staff are not usually required to witness the pressure testing of BOP components, they should ensure that a proper pressure test was conducted by the operator.
 - The on-site supervisors should be questioned as to the exact method (and tools) used to conduct the pressure test.
 - If it is determined that an improper test was conducted (e.g. failure to test BOP to wellhead connection) operations must be suspended until a proper test is carried out. In some cases this may mean setting a packer in the production casing.

Test Requirements

2. With the exception of wells in Class I, each BOP, the connection between the stack and the wellhead, the safety (stabbing) valve, the bleed-off manifold, and the bleed-off and kill lines must be pressure tested.
 - A low-pressure test of 1400 kPa must be conducted on each ram preventer. This test is to be conducted first.
 - A high pressure test must be conducted on each ram preventer, the full opening safety valve and the connection between the stack and the wellhead. The pressure required shall be the wellhead pressure rating or the formation pressure whichever is the lesser.
 - The annular preventer shall be pressure tested to 7000 kPa or the formation pressure whichever is the lesser.
 - The BOP to wellhead connection does not require testing when an electrical submersible pump is in the well (see item 14).
3. All valves in the bleed-off manifold must be tested individually (at the same pressure as the manifold) to confirm their isolation.
 - Adjustable chokes do not require testing.
4. For a satisfactory pressure test, all components must maintain a **stabilized** pressure of at least 90 per cent of the test pressure over a 10-minute interval or over a 2-minute interval for each well in a Heavy Oil/Oil Sands * secondary recovery well servicing program subsequent to weekly 10-minute pressure tests: (see item 13).

* A Primary Recovery Heavy Oil/Oil Sands Well, for the purpose of this manual, is defined as a well having a sandface reservoir pressure equal to or less than the hydrostatic pressure that would be exerted at the sandface if the well were filled with formation fluids. A Secondary Recovery Heavy Oil/Oil Sands Well (EOR), for the purpose of this manual, is defined as a well having a sandface reservoir pressure greater than that described above, by virtue of injection into the formation of fluids(s) other than water at ambient temperatures. This includes all

Handling Test Deficiencies

5. See Section 320(3) if deficiencies occur during the witnessing of a pressure test.

Testing Using Test Stump or Test Flange

6. A test stump or test flange may be used for pressure testing all BOP components
7. Stump or flange testing is recommended over wellhead testing as it allows for the detection of problems before the wellhead is removed.
8. Although there are many ways BOPs may be stump or flange tested, the following points may serve as a guide to the procedures commonly used by industry.
 - The test stump or flange must be equipped in such a fashion that test fluid can be introduced below the lowest preventer in order to test each BOP component.
 - A pup joint is generally run into the BOPs and secured to the test stump or flange to permit the testing of the pipe rams and the annular preventer (a tubing collar is usually welded to the stump or flange).
 - The stabbing valve may be mounted on top of the pup joint to allow for the testing of the stabbing valve (pup joint must be perforated to permit the simultaneous testing of the valve with either the pipe rams or the annular preventer).
 - In some cases, contractors will only use the stump or flange to pressure test the blind rams. The remaining preventers will be tested on the wellhead against the dognut (pup joint screwed into dognut to carry out tests).

Testing BOP to Wellhead Connection

9. The BOP to wellhead connection also requires pressure testing when stump or flange testing has been performed.
10. If no tubing is in the well, and a formation is open to the wellbore
 - a packer may have to be run in the casing to permit pressure testing.
 - the dognut may be run on the bottom of a joint of tubing and landed in the tubing spool (set screws secured). Testing can then take place by pressuring up below a closed preventer.

wells that are a part of an active EOR project approved by the EUB and any offset wells within 1 km of an EOR well within the project.

11. If tubing is in the well, and a formation is open to the wellbore
 - a pup joint can be screwed into the dognut and testing take place by pressuring up below a closed preventer (the pup joint will have to be blanked on bottom and perforated above the blank if the stabbing valve is to be pressure tested along with BOPs).

Testing with Slip-type Wellheads

12. In the case of slip-type wellheads a proper tubing hanger (dognut) can be landed in the tubing spool after the slips, seals, and tubing head adapter have been removed. A pressure test can be carried out by following step 11 above.

Dognut Fails Pressure Test

13. If the dognut fails to hold pressure, it is acceptable to maintain the required pressure on the wellhead while the pipe rams (or annular), as well as the wellhead connection, are monitored for leaks. If it can be positively determined that no leaks exist, the test may be considered satisfactory.

Wellhead Connection Test/Electrical Submersible Pump

14. A pressure test of the wellhead connection cannot be conducted when a well contains an electric submersible pump (cable protrudes from tubing hanger). This is acceptable.

265: Well-Site Conditions

Condensate Requirements

These rules must be followed when condensate or other low flashpoint hydrocarbons are being used at the well (see Section 320(2) for method of handling deficiency).

1. No open tanks may be used for storing or gauging or measuring the pumping rate.
2. A minimum distance of 50 m must be maintained between the wellhead and storage tank.
3. Positive shut-off valves must be installed between the pump and wellhead.
4. A check valve must be installed between the pump and the well to prevent backflow from the well.
5. All surface lines downstream from the pump must be pressure tested to 10 000 kPa (1500 psig) above anticipated maximum pressure.
6. No significant wastage may occur.
7. The operator must obtain approval from the Drilling and Production Department in Calgary to use condensate for the purpose of hydraulic fracturing.

DST Equipment

8. When a drill-stem test is either in progress or being rigged up, ensure that there is a means of circulating fluid through the drill string (reverse circulating sub).
9. A remote-controlled master valve must be installed on the testing head.
 - If a DST unit is on the lease, but not rigged up, check if this equipment is available.
 - Notify the on-site supervisor of any problems noted.

Engine Exhausts

10. An exhaust pipe from an internal combustion engine located within 25 m (75 feet) of a well must
 - be constructed to prevent any emergence of flame along its length or at its end.
 - end not closer than 6 m (20 feet) to the vertical centreline of the well, and must be directed away from the well.

For directional wells where the casing and BOP's are set on an angle, the measurement is from the top of the flow tee position.

Containment of Drilling Fluids

11. All drilling fluids, whether they be contained in a sump, lined pits, trenches or buried tanks, must be properly contained.
 - Disposal of waste lubricants, oil, glycol, etc. into a sump or other site is NOT permitted. These materials must be disposed of in accordance with Appendix 1100.

Sump Construction

12. CPA issued "Environmental Operating Guidelines" for the petroleum industry in September, 1988. Along with many other recommendations, this document suggested that the following guidelines be recognized during sump construction and operation.
 - The sump should be excavated from an impervious, undisturbed subsoil and should be shaped to allow maximum reuse of clear water for mud make-up.
 - The sump must be adequately sized to allow for the anticipated volume of drilling fluid. Although certain drilling variables may be expected, 1 m of freeboard should be considered.
 - The sump should be located on the high side of the lease and as far away as possible from any bodies of water.
 - Rain and snow run-off diversion ditches may be necessary if the site topography poses a problem or if the area is considered sensitive.

- Sumps constructed in permeable soil must be sealed with clay or a synthetic liner, or any other approved technique which will prevent fluid leakage.
- Well workover and completion wastes must be isolated from the main sump upon completion of well drilling operations.
- See ERCB Guide G-50 for sump guidelines.

Handling Containment and Spillage Problems

13. Initiate appropriate corrective action if it appears that sump fluids, workover or wellbore fluids, mud additives, chemicals, fuel, or any other materials have been spilled on or off lease.
 - Consult with Area Supervisor if assistance in determining the best clean-up method is required.
 - See Section 320(2) for method of handling deficiency.

270: Operator and Contractor Inspections

Daily Inspections

1. The operator's (if available) and contractor's on-site supervisor must conduct a Daily "walk around" Inspection of the rig in an effort to spot deficient well control and safety related items.
2. Ideally, this inspection should be carried out in conjunction with the daily mechanical testing of the BOP equipment.

Recording Daily Inspections

3. The on-site supervisors are to record Daily Inspections on the tour reports.
 - A comment such as "Daily Inspection Completed" would be appropriate.
 - It is not necessary for the supervisors to sign or initial the above statement. The daily signing of the tour reports is all the verification necessary.
4. The inspector should check the tour reports to ensure that these inspections are being conducted.
 - If deficiency noted, mark inspection item 108 with an "X" in the "NO" box, and make an appropriate comment on the inspection report.

Do not mark rig or non-rig related summary boxes 50 and 100 unsatisfactory if this is the only deficiency noted during the inspection.

Detailed Inspections

5. The operator's (if available) and contractor's on-site supervisor must individually or jointly conduct a Detailed Inspection of the rig.

6. Ideally this inspection should be completed during the initial rig up and weekly thereafter. A weekly crew BOP drill would be an appropriate time to conduct the weekly Detailed Inspection.
7. For critical wells, inspections must be completed within the 24-hour period prior to initiating operations in the H₂S or abnormally pressured formation.
8. A comprehensive check sheet, including EUB inspection items listed as High Risk and Low Risk in Appendix 1045, should be used for this inspection.

Recording Detailed Inspections

9. The on-site supervisors are to record Detailed Inspections on the tour reports.
 - A comment such as “Detailed Inspection Completed” would be appropriate.
 - It is not necessary for the supervisors to sign or initial the above statements. The daily signing of the tour reports is all the verification necessary.
10. The inspector should check the tour reports to ensure that these inspections are being conducted.
 - If deficiency noted, mark inspection item 108 with an “X” in the “NO” box, and make an appropriate comment on the inspection report.

Do not mark rig related or non-rig related inspection summary boxes 50 and 100 unsatisfactory if this is the only deficiency noted.

Reviewing Detailed Inspection Form

11. It may be necessary to review the Detailed Inspection Form used by the operator and contractor if a number of deficiencies surface during an EUB inspection. This may indicate an incomplete inspection is being conducted by the operator and/or contractor.

275: Well-Site Records and Signs

Warning Signs in H₂S Area

1. If there is reasonable expectation of encountering H₂S gas during servicing operations, the operator must post a poisonous gas warning sign on or near the rig.
 - If a warning sign is posted at a well site where no H₂S is anticipated the inspector should require that the sign be removed. The indiscriminate posting of signs may tend to decrease the importance of a sign at a well site where H₂S may truly be encountered.

- Recording Pressure Test**
2. Check the tour sheets to determine if the tests were conducted.
 - Ensure that the following were noted on the tour sheets:
 - BOP tested (all components).
 - Test duration.
 - Low- and high-pressure test details
- Recording Daily Mechanical Test**
3. Check the tour sheets to determine if the BOPs have been mechanically tested daily.
 - Ensure actual components checked by crews are recorded (e.g. “Rig Service and BOP Check” is not adequate).
 - The blind rams do not have to be tested if a special trip from the hole is required.
- Shop Servicing Records for BOPs and Flexible Bleed-off and Kill-line Hoses**
4. All BOPs and bleed-off and kill-line hoses require shop servicing and pressure testing every 3 years.
 5. The acceptable servicing and testing requirements are specified in Informational Letter IL 88-11 entitled Shop Servicing and Testing of Blowout Preventers and Flexible Bleed-off and Kill-line Hoses. This document is available through our Drilling and Production Department in Calgary.
 6. During service rig inspections, the contractor should be requested to supply evidence that proper servicing and testing have been completed.
- Recording Weekly Diesel Engine Tests**
7. Check the tour sheets to ensure that the rig has tested its air shut-offs
 - before conducting any servicing operations on a completed well.
 - at least once in every 7-day period during the servicing of the well.
- Recording Operator and Contractor Inspections**
8. Check the tour sheets to ensure that the Rig Manager and operator's representative are conducting “Daily” and “Detailed” inspections (see Section 270).

Smoking Regulations

1. No person shall smoke within 25 m of a well, separator, oil storage tank, or other unprotected source of ignitable vapour, or on a rig or derrick at a well site.

Handling Smoking Violations

2. If someone is found smoking in contravention of the regulations, follow one of three options:

- Verbal warning

Explain the reason for the regulation and the possibility of prosecution.

- Inform Contractor and Operator

By telephone or letter, notify senior personnel of the servicing contractor and the operator about the infraction. Request that they investigate the problem and report the actions taken. Alternatively, hold a meeting to discuss the problem.

- Prosecute

If it is evident that the first two options are not effective, prosecution may be used as a last resort. The regulations allow the Board to prosecute the contractor, who is the employer of the person, and the licensee of the well, whether or not they had any knowledge of the smoking, or whether or not they had taken any steps to prevent smoking from occurring. It is not the Board's intention to prosecute the employee only. When a recommendation is being made to prosecute, include evidence of the attempt to utilize the first two options.

If prosecution is believed to be necessary, gather the following evidence:

- date and time of the occurrence,
- full name (no initials), address, driver's licence number, birth date, any other details of the person in violation, and all witnesses' names,
- measure distance from the well to the location of the offence (have person witness measurement).

Even if prosecution is not necessary, gathering evidence may be a good deterrent to convince the person of the seriousness of the violation.

Penalties for Smoking

3. The Oil and Gas Conservation Act provides for the following penalties:
 - (a) if a corporation, a fine of not less than \$300.00 nor more than \$1000.00, and
 - (b) if a person, a fine of not less than \$50.00 nor more than \$500.00, and in default of payment, a term of imprisonment not exceeding 6 months.

300: Completing the Inspection Report

305: General Information

Report Completion	An inspection report should be completed even if only one rig or non-rig related item is examined. See Appendix 1005 for examples of completed reports.
Contractor Name	Enter the name in sufficient detail to enable the coding staff in Calgary to positively identify the contractor.
Number	Leave blank.
Rig Number	Enter the unique 4-character number identifying the rig. Fill in all spaces, using zeros when necessary. Examples: For rig #1, enter 0001. For rig 7E, enter 0007, and print "RIG 7E" above the line. For rig #C-2, enter 0002, and print "Rig C-2" above the line. For rigs Mr. Jim, Mr. Nick, Mr. Digger, enter OJIM, NICK, DIGG.
Rig Type	S-service rig.
Well I.D.	Enter the 13-character "unique identifier" taken directly from the well licence (if available). Note: Fill in all spaces. Check the UID in the tour reports and on the well name sign or plate. The UID obtained on the lease must be checked at the office through the Basic Well Data System. For directionally drilled wells, be sure to enter the unique ID location for the licence and not the surface location <ul style="list-style-type: none">- The LE section will change when a specific LSD has more than one well. Ensure the correct LE is used and check it back at the field office through the BWD System.- The final space refers to the event sequence and depends upon the number of zones completed, re entry, deepening of the well, etc. It must be checked back in the office through the BWD system.
Operator Name	Enter the name of the company shown as "licensee" on the well licence (may be unit operator in some cases).
Operator Number	Leave blank.
Inspection Type	Partial - Circle when any inspection results are noted, except P when a pressure test of the blowout preventers has been witnessed.

Complete - Circle when a pressure test of the blowout preventers
C has been witnessed, in whole or in part.

Area Office

Enter the 2-digit code indicating the Board office that conducted the inspection.

- 03 - Wainwright
- 04 - Calgary (S)
- 05 - Bonnyville
- 06 - Drayton Valley
- 07 - Edmonton
- 08 - Medicine Hat
- 09 - Red Deer
- 10 - Grande Prairie

Inspection Date

Enter the date the inspection was completed.

Well Class

Enter the class of well being inspected.

- Be sure to record the required servicing class and not the class of BOP stack in service.

Rig Manager

Enter the name of the Rig Manager present at the rig during the inspection.

- if the Rig Manager present is relieving the regular Rig Manager, enter the regular's name also.

Rig Status

Enter the status of the rig during the inspection.

- Check the tour sheet since the status may not be obvious. If in doubt, ask the Rig Manager or Driller.

310: Mechanical Tests

Description and Location of Equipment and Controls

Record: Record

1. Accumulator make, number of bottles, capacity, design pressure, precharge, and pressures before and after mechanical check.
2. The time required to recharge the accumulator system.
3. The number of nitrogen bottles, their capacity, and their combined average pressure (record each bottle's capacity and pressure if bottles not the same size or bottles are isolated independently).
4. Number and type of BOP controls, and the number, type, and distance of remote controls.
5. Whether locking handles for ram type preventers are available, or whether the rams have automatic locking devices.

315: Inspection Results

General

- For inspection procedures and test requirements, see Section 200 - Conducting the Inspection. The corresponding section number is shown beside each item below.
- Satisfactory inspection results in this section are marked with an “X” in the appropriate box.
- If any one aspect of a test or condition is unsatisfactory, code the “NO” box either (1) Low Risk, (2) High Risk, or (3) Both.
- Mark inspection results based on the initial check, not after repair or adjustment.
- If an unsatisfactory item is corrected during the inspection, make note of it in the Remedial Action Section.
- If an item is not checked, leave both boxes blank.
- The following numbers refer to the items on the rig inspection form.

YES/NO

- 50 - Mark an “X” in the “YES” box only if all of the following inspection results in boxes 52-91 are either marked satisfactory or left blank. If any deficiencies are noted in boxes 52-91, mark an “X” in the “NO” box.
- If pressure test being conducted on BOP stack, do not mark rig inspection or any rig related items unsatisfactory.
- Non-rig related items may still be marked as unsatisfactory.

BOP System

- 52 - Section 210, 1 to 14; Section 275, 4 to 6
- 53 - Section 210, 15 to 22
- 54 - Section 215, 6
- 55 - Section 210, 24 to 26
- 56 - Section 245, 1 to 5
- 57 - Section 215, 1 to 5 and 7; Section 225, 1 to 9, 1 to 8, 1 to 12; Section 235, 1 to 14; Section 240, 1 to 5
- 60 - Section 210, 23

Training and Procedures

- 71 - Section 220, 1 to 9
- 72 - Section 210, 18
- 74 - Section 220, 10

- Rig Other**
- 80 - Section 230, 7, 10 and 11; Section 250, 1 and 2
 - 81 - Section 280, 1 to 3
 - 82 - Section 265, 8 and 9
 - 83 - Section 275, 1
 - 84 - Section 260, 1 to 14; Section 275, 2
 - 85 - Section 275, 3
 - 86 - Section 275, 7
- Engines**
- 90 - Section 230, 1 to 6, 8 and 9
 - 91 - Section 265, 10
- Non-rig Related**
- 100 - Mark “YES” only if items 101 to 107 are either satisfactory or left blank
- Miscellaneous**
- 101 - Section 250, 3 and 4
 - 102 - Section 250, 5
 - 103 - Section 250, 6
 - 104 - Section 265, 1 to 7
 - 105 - Section 255, 1 and 2; Section 265, 11 to 15
 - 106 - Record the licence number beside this line, if well re-entry taking place (operator not original licensee)
 - 108 - Section 270, 1 to 11; Section 275, 8
- Special Well**
- 114 - Section 330
- Letter Sent**
- Check “YES” if a letter is to be sent by the Area Office.
 - Check “NO” if the area office is not sending a letter.
- BOP Stack Diagram**
- This stack diagram is generalized to fit all possible situations.
 - In cases where all the parts of the diagram are not needed, the diagram of the stack should start at the top and work down using each box as one component of the stack.
 - The smaller squares that appear between the individual components represent spools. Indicate whether or not these spools are present.
 - At whatever point the stack diagram is complete, draw a horizontal line across and vertical lines down to indicate the wellhead.

- Note all brand names, size, and pressures on the left hand side of the BOP stack diagram.
- Show the relative position of all flexible hoses, valves, chokes, gauges, flare lines, degasser; and if a manifold is required, indicate its components and its position within the circulation system.
- In all cases use the symbols shown in Appendix 1010.

320: Remedial Action

General

1. Each item marked “NO” under Inspection Results requires a description of
 - the deficiency noted.
 - the type of remedial action required.
2. Do not mark the rig inspection unsatisfactory (item 50) if inspection items 101, 102, 103, 104, 105, 106, 107, and 108 are found deficient. These items are considered secondary with respect to well control, and not related to the rig.
 - Excluding item 108, these items are still to be handled as high or low risk deficiencies (see Section 320(15)).
 - With the exception of item 108, mark item 100 unsatisfactory if the above deficiencies occur.
3. Deficiencies noted during the witnessing of a pressure test must only be recorded in the remarks section of the report (e.g. air shut-off must be repaired within 4 hours and the Red Deer office advised accordingly).
4. If more than one inspection form is needed to provide descriptions, ensure that
 - the top right-hand corner is marked page 2.
 - the top two lines of boxes are completed.
 - the remainder of the form, other than the Remedial Action Section, is left blank.

Handling High Risk Deficiencies Definition*

5. A High Risk deficiency is any violation of regulations which occurs when a formation is open to the wellbore and which occurs prior to, during, or after the installation of appropriate BOP equipment and which could

* From the Service Rig Inspection and Enforcement Committee, 1986.

- restrict the crew's ability to safely detect and circulate out a kick or shut in the well.
- contribute to an operational failure of any BOP equipment.
- impair the crew's ability to maintain control of the well.

Recording High Risk Deficiencies

6. Indicate High Risk deficiencies on the inspection report by writing the words High Risk after the appropriate inspection item number (e.g. #53 High Risk Pressure gauge in manifold inaccurate).
7. It is important to designate which items are High Risk since there may be several deficiencies which relate to a specific inspection item, some of which are not High Risk.
 - See Appendix 1045 for list of High Risk deficiencies.

Action Required for High Risk Deficiencies

8. Servicing operations should be suspended immediately whenever a High Risk deficiency is detected. Do not overlook a rig shut-down because servicing operations are nearly completed. A shut-down must take place provided it is safe to do so.
 - If the service rig is conducting drilling operations allow the rig to continue circulating until repairs are made. As long as the rig can circulate, hole conditions should not be jeopardized.
9. Generally, drill-stem testing and logging operations should be permitted to continue, provided the deficiency does not specifically relate to these operations.
 - It may be necessary to restrict the pulling of a test until the deficiency is corrected (allow circulation through reverse circulating sub).
 - It may also be necessary to allow the pulling of a small segment of the test string to prevent the sticking of the tail pipe during a conventional test (relocate tail pipe to consolidated portion of wellbore).
10. Inform the operator and contractor of the shut-down. Do not allow operations to resume until the deficiency is corrected.
 - Remain at rig if repairs can be completed in a short time.
 - If lengthy repairs are necessary have operator or contractor confirm, by telephone, that deficiencies have been corrected (provide area office, home, or other telephone number).
 - If practical, conduct reinspection.

- Use discretion when allowing rig to resume operations before, or without, being reinspected.

11. Advise Area Supervisor of rig shut-down.

- Area office may wish to inform Calgary.

Follow-up to High Risk Deficiencies

12. A letter describing the deficiency should be sent to the operator with photocopies directed to the contractor and the Field Operations Department.

- Attach photocopy of rig inspection report to operator and contractor letters.

13. If deficiencies repeatedly recur for a particular operator and/or contractor, a meeting should be held to discuss their respective inspection records (consider shut-down until meeting with operator's and contractor's senior personnel takes place on site).

- Area office should initiate this action.
- Co-ordinate meetings through the Field Operations Department and Drilling/Servicing Coordinator.
- Involvement of more than one area office may be needed.

Operator and/or Contractor Indicated Shut Down (High Risk Deficiencies)

14. If the rig has been shut down by the operator and/or contractor to remedy a High Risk deficiency, the inspector should not mark the rig unsatisfactory, provided a list of the deficiencies to be corrected has been prepared by the rig supervisors.

- The deficiencies do not have to be recorded in the tour reports—any form of documentation is satisfactory provided the list can be produced the moment an inspector arrives at the rig.
- A comment should only be made on the inspection report that a High Risk deficiency existed upon arrival at the rig and that the deficiency was being corrected by the rig supervisors.
- The inspector should ensure that operations are not resumed until the deficiency is corrected.

Handling Low Risk Deficiencies Definition

15. Deficiencies rated as Low Risk are those contraventions of the regulations which should not affect the operation of the BOP system or restrict the crew's ability to control the well.

16. These deficiencies are nevertheless contraventions of the regulations and therefore should not be considered unimportant.

- See Appendix 1045 for list of Low Risk deficiencies.

Recording Low Risk Deficiencies

17. These deficiencies should be designated as Low Risk on the Inspection Report.
- Simply record the inspection item and specify the deficiency (e.g. #90 Diesel engine shut-off on rig motor failed to operate).

Action Required for Low Risk Deficiencies

18. Operations are not normally suspended, although suspension may be necessary in some instances if
- the rig has a history of similar deficiencies.
 - numerous deficiencies are identified.
19. A depth or time limitation is usually assigned for the correction of deficiencies.
- Time limitations may range from immediate to next hole.
 - Determine, through consultation with the rig supervisors, what reasonable time-frame should be imposed. Consider the time needed to make repairs or to acquire and install replacement parts.
 - Do not overlook imposing reasonable deadlines even if servicing operations are nearly completed.
20. If a reinspection is not possible, have rig supervisors confirm, by telephone, that deficiencies have been corrected.
- Provide area office, home, or other telephone number.

Follow-up to Low Risk Deficiencies

21. A letter describing the deficiencies is usually not required, however, if the Driller's BOP certificate has expired a letter may be required (see Section 220 pg 2).
- A letter may be appropriate under other circumstances as well.
22. A letter or meeting may be necessary if deficiencies keep recurring for a particular operator and/or contractor.
- Area office should initiate this action.
 - Co-ordinate efforts through the Field Operations Department.
 - Photocopy of rig inspection report must accompany all letters to operators and contractors.

Operator and/or Contractor Initiated Remedial Action (Low Risk Deficiencies)

23. If the operator and/or contractor have detected a Low Risk deficiency and have undertaken appropriate corrective action, the inspector should not mark the rig unsatisfactory, provided a list of the deficiencies to be corrected has been prepared by the rig supervisors.
- The deficiencies do not have to be recorded in the tour reports—any form of documentation is satisfactory provided the list can be produced the moment an inspector arrives at the rig.
 - A comment should only be made on the inspection report that a Low Risk deficiency existed upon arrival at the rig and that the deficiency was being corrected by the rig supervisors.
 - The inspector should ensure that an appropriate deadline for correcting the problem has been established by the rig supervisors.
 - The inspector should ensure that he is advised by the rig supervisors once the deficiency has been corrected.

325: Signatures and On-Site Discussions

- | | |
|---|--|
| Area Office | - Enter the name of the area office. |
| Inspector's Signature | - Sign your name (print it above also if your signature is illegible). |
| Report Review with On-site Supervisors | <ul style="list-style-type: none">- Review the form with the Rig Manager and operator's representative.- Discuss any remedial action required. |
| On-site Supervisors' Signatures | <ul style="list-style-type: none">- Ask the representatives to sign the form. If either representative refuses to sign the form or if either representative is not at the lease, make appropriate comments in the remarks section of the report.- Call Area Supervisor when a representative refuses to sign report. Discuss inspection details.- Area Supervisor should consider calling operator and contractor to resolve contentious issues. |
| Recording Rig Down-time | - Record the total time (to the nearest quarter hour) that operations were interrupted to carry out the rig inspection or subsequent remedial action. |

330: Special Wells

Unsatisfactory Inspection – Critical Sour Well

- If a High Risk deficiency or several Low Risk deficiencies are noted during an inspection of a service rig working on a critical sour well, a follow-up inspection must be conducted before operations are completed.

1000: Appendices

1005: Sample Inspection Reports

The next three pages provide examples of completed inspection reports (Figures 1005-A, 1005-B, and 1005-C).



Energy Resources
Conservation Board
840 Fifth Avenue SW
Calgary, ALA. T2P 3G4

DRILLING & SERVICING OPERATIONS INSPECTION REPORT

FIELD OPERATIONS DEPARTMENT

GENERAL INFORMATION

CONTRACTOR NAME: Chucky Service Ltd NUMBER: RIG NO.: 0001 RIG TYPE: S WELL ID: 100133104901W400

OPERATOR NAME: T.E.C. INDUSTRIES Ltd NUMBER: INSPECTION TYPE (CIRCLE): P AREA OFFICE: 03 INSPECTION DATE: 950602 WELL CLASS: 01

RIG MANAGER: C. MOORE CURRENT DEPTH (m): PROJECT T.D. (m): CASING SETTING DEPTH (m): RIG STATUS: Running Tubing

MECHANICAL TESTS

DESCRIBE ALL TESTS CONDUCTED, INCLUDING LOCATION OF EQUIPMENT AND CONTROLS.

ACCUMULATOR	RECHARGE PUMP	BOP CONTROLS		BOP	TIME TO OPERATE	PRESSURE TEST (MPa)		
		NO. ON FLOOR	TYPE			LOW	HIGH	TIME
MARK: <u>Shaffer</u> NO. BOTTLES: <u>2</u>	TIME: <u>1</u> min	NO. ON FLOOR: <u>1</u>	TYPE: <u>Hyd</u>	ANNULAR/MCR: <u>Tubing Ram</u>	0.013			
CAPACITY: <u>76L</u>	IN BOTTLES: <u>1</u>	NO. REMOTE: <u>1</u>	TYPE: <u>Hyd</u>	RAM: <u> </u>				
DESIGN PRESSURE: <u>17.10/10.10</u> MPa	NUMBER: <u>1</u>	TYPE: <u>Hyd</u>	TYPE: <u>Hyd</u>	RAM: <u> </u>				
PRECHARGE PRESSURE: <u>0.7/10.10</u> MPa	CAPACITY: <u>42L</u>	TYPE: <u>Hyd</u>	TYPE: <u>Hyd</u>	RAM: <u> </u>				
PRESSURE BEFORE: <u>13.15/10.10</u> MPa	AVERAGE PRESSURE: <u>17.15/10.10</u> MPa	TYPE: <u>Hyd</u>	TYPE: <u>Hyd</u>	RAM: <u> </u>				
PRESSURE AFTER: <u>12.18/10.10</u> MPa		TYPE: <u>Hyd</u>	TYPE: <u>Hyd</u>	RAM: <u> </u>				

INSPECTION RESULTS (CODE: dash = 1 surface - = 2)

YES NO

80. RIG APPEARS SATISFACTORY ?

BOP SYSTEM

- 82. BOP TYPE, RAM SIZE & PRESSURE RATING SATISFACTORY ? *
- 83. BLEED-OFF & KILL LINES APPEAR SATISFACTORY ? *
- 84. NON-STEEL HYDRAULIC LINES FIRE SHEATHED ?
- 85. DRILL-STEMMING VALVES READILY ACCESSIBLE ? *
- 86. EQUIPMENT ADEQUATELY HEATED ? *
- 87. BOP EQUIPMENT & CONTROLS WORKABLE & PROPERLY CONNECTED ? *
- 88. DRILL-STEMMING PRESSURE AVAILABLE AT CHARGE CONTROL ? *
- 89. MUD-GAS SEPARATOR ADEQUATELY CONNECTED ?
- 90. REQUIRED CASING WEAR TESTS BEING PERFORMED ?

TRAINING & PROCEDURES

- 70. DRILLER HAS P.I.T.S. FIRST LINE CERTIFICATE ? *
- 71. CREW BOP TRAINING APPEARS SATISFACTORY ? *
- 72. MUD VOL. MEAS. & HOLE FILL PROCEDURES SATISFACTORY ? *
- 73. PERSON READILY AVAILABLE WITH P.I.T.S. SECOND LINE CERTIFICATE ? *
- 74. DRILLER HAS P.I.T.S. WELL SERVICING CERTIFICATE ? *

RIG OTHER

- 80. WELL TO FLAME-TYPE EQUIPMENT 25 m ?
- 81. SMOKING RULES BEING OBSERVED 25 m ?
- 82. DET EQUIPMENT SATISFACTORY ?
- 83. WARNING SIGNS POSTED IN H₂S AREAS ?
- 84. BOP PRESSURE TESTS RECORDED & TEST PROCEDURES SATISFACTORY ?
- 85. DAILY MECHANICAL TESTS RECORDED ?
- 86. WEEKLY DIESEL ENGINE TESTS RECORDED ?

ENGINES

- 90. DIESEL ENGINE SHUT-OFFS STOP ALL ENGINES ?
- 91. ENGINE EXHAUSTS SATISFACTORY ?

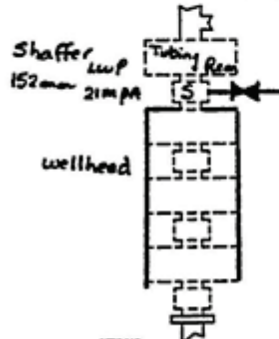

YES NO

100. NON-RIG RELATED ITEMS APPEAR SATISFACTORY ?
- MISCELLANEOUS
- 101. WELL TO END OF FLAME LINE 30 m ?
 - 102. RUBBISH BURN PILE 30 m ?
 - 103. CRUDE OIL STORAGE TANK 30 m ?
 - 104. CONDENSATE RULES BEING OBSERVED ?
 - 105. FLUIDS PROPERLY CONTAINED ?
 - 106. LICENSE POSTED & NUMBERED ?
 - 107. REQUIRED DEVIATION SURVEYS RUN ?
 - 108. CONTRACTOR & OPERATOR INSPECTIONS RECORDED ?
- LETTER SENT BY AREA OFFICE ?

REMEDIAL ACTION REQUIRED

Rig Satisfactory - Crew co-operation Good!

Thanks.

AREA OFFICE: Wainwright BOARD REPRESENTATIVE: E. Bray CONTRACTOR REPRESENTATIVE: C. Moore OPERATOR REPRESENTATIVE: T. Cook RIG DOWN TIME: 00:15



Energy Resources
Conservation Board
840 Fifth Avenue SW
Calgary, Alta. T2P 3G4

DRILLING & SERVICING OPERATIONS INSPECTION REPORT

FIELD OPERATIONS DEPARTMENT

GENERAL INFORMATION

CONTRACTOR NAME: Willy's Oil Well Servicing NUMBER: BOP NO.: 0003 BOP TYPE: 5 WELL ID: 100111401213W400

OPERATOR NAME: wild Cat Exploration NUMBER: INSPECTION TYPE (CIRCLED): (P) C AREA OFFICE: 0.8 INSPECTION DATE: 950602 WELL CLASS: 0.2

RIG MANAGER: P. Smith CURRENT DEPTH (m): 1305 PROJECT T.D. (m): CASING SETTING DEPTH (m): BOP STATUS: Circulating

MECHANICAL TESTS DESCRIBE ALL TESTS CONDUCTED, INCLUDING LOCATION OF EQUIPMENT AND CONTROLS.

ACCUMULATORS	RECHARGE PUMP	BOP CONTROLS		BOP	TIME TO OPERATE	PRESSURE TEST (MPa)			
		NO. ON FLOOR	TYPE			LOW	TIME	HIGH	TIME
MAKE: <u>Wagner</u>	TIME: <u>1</u> min	NO. ON FLOOR: <u>2</u>	TYPE: <u>Hyd</u>	ANNULAR/NO. PIPE: <u>0103</u>					
CAPACITY: <u>76 L</u>	NO. BOTTLES: <u>1</u>	NO. REMOTE: <u>2</u>	TYPE: <u>Hyd</u>	RAM: <u> </u>					
DESIGN PRESSURE: <u>21.0/0.10</u> MPa	CAPACITY: <u>42 L</u>	DISTANCE: <u>0.17</u> m	TYPE: <u> </u>	RAM: <u> </u>					
PRECHARGE PRESSURE: <u>0.17/0.10</u> MPa	AVERAGE PRESSURE: <u>1.5/2.0/0.0</u> MPa	HAND WHEELS: <u>✓</u>	TYPE: <u> </u>	RAM: <u> </u>					
PRESSURE BEFORE: <u>1.16/0.10</u> MPa			TYPE: <u> </u>	RAM: <u> </u>					
PRESSURE AFTER: <u>1.14/2.0/0.0</u> MPa			TYPE: <u> </u>	RAM: <u> </u>					

INSPECTION RESULTS (0000 significant - 1 minor - 2)

- YES NO
50. BOP APPEARS SATISFACTORY ?
- BOP SYSTEM
- 52. BOP TYPE, RAM SIZE & PRESSURE RATING SATISFACTORY ? *
 - 53. BLEED-OFF & KILL LINES APPEAR SATISFACTORY ? *
 - 54. NON-STEEL HYDRAULIC LINES FIRE SHEATHED ?
 - 55. DRILL-STRING VALVES READILY ACCESSIBLE ? *
 - 56. EQUIPMENT ADEQUATELY HEATED ? *
 - 57. BOP EQUIPMENT & CONTROLS WORKABLE & PROPERLY CONNECTED ? *
 - 58. DRILL-STRING PRESSURE AVAILABLE AT CHOKE CONTROL ? *
 - 59. MUD-GAS SEPARATOR ADEQUATELY CONNECTED ?
 - 61. REQUIRED CASING WEAR TESTS BEING PERFORMED ?
- TRAINING & PROCEDURES
- 70. DRILLER HAS P.I.T.S. FIRST LINE CERTIFICATE ? *
 - 71. CRED. BOP TRAINING APPEARS SATISFACTORY ? *
 - 72. MUD VOL. MEAS. & HOLE FILL PROCEDURES SATISFACTORY ? *
 - 73. PERSON READILY AVAILABLE WITH P.I.T.S. SECOND LINE CERTIFICATE ? *
 - 74. DRILLER HAS P.I.T.S. WELL SERVICING CERTIFICATE ? *
- RIG OTHER
- 80. WELL TO FLAME-TYPE EQUIPMENT 25 m ?
 - 81. SMOKING RULES BEING OBSERVED 25 m ?
 - 82. DIST EQUIPMENT SATISFACTORY ?
 - 83. WARNING SIGNS POSTED IN H₂S AREAS ?
 - 84. BOP PRESSURE TESTS RECORDED & TEST PROCEDURES SATISFACTORY ?
 - 85. DAILY MECHANICAL TESTS RECORDED ?
 - 86. WEEKLY DIESEL ENGINE TESTS RECORDED ?
- ENGINES
- 90. DIESEL ENGINE SHUT-OFFS STOP ALL ENGINES ?
 - 91. ENGINE EXHAUSTS SATISFACTORY ?

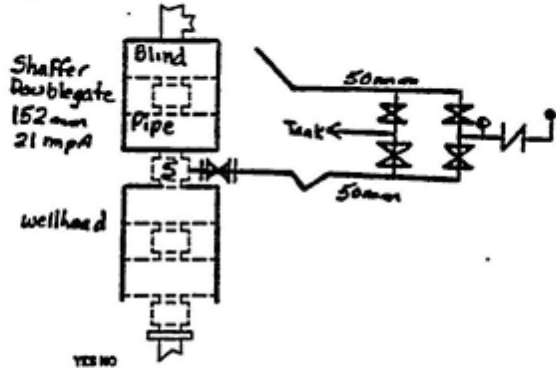

- YES NO
100. NON-IRIG RELATED ITEMS APPEAR SATISFACTORY ?
- MISCELLANEOUS
- 101. WELL TO END OF FLAME LINE 80 m ?
 - 102. RUBBISH BURN PILE 80 m ?
 - 103. CRUDE OIL STORAGE TANK 80 m ?
 - 104. CONDENSATE RULES BEING OBSERVED ?
 - 105. FLUIDS PROPERLY CONTAINED ?
 - 106. LICENSE POSTED ? NUMBER:
 - 107. REQUIRED DEVIATION SURVEYS RUN ?
 - 108. CONTRACTOR & OPERATOR INSPECTIONS RECORDED ?
- LETTER SENT BY AREA OFFICE ?

REMEDIAL ACTION REQUIRED

#53 (significant) Valve Handle missing on Flanged valve. corrected during inspection

#57 (serious) Pipe Rams would not function from remote position operations were suspended. Repairs completed at 2:00 p.m. Rams operated o.k. operations were allowed to resume.

AREA OFFICE: Medicine Hat BOARD REPRESENTATIVE: Pat Smyl CONTRACTOR REPRESENTATIVE: P. Smith OPERATOR REPRESENTATIVE: Derry Wright BOP DOWN TIME: 2:00



Energy Resources
Commission Board
640 Fifth Avenue SW
Calgary AB T2P 3G4

DRILLING & SERVICING OPERATIONS INSPECTION REPORT
FIELD OPERATIONS DEPARTMENT

GENERAL INFORMATION

CONTRACTOR NAME: May Bros. Well Service NUMBER: 010109 RIG NO: S WELL ID: 100131303901W5106

OPERATOR NAME: Bashaw Petroleum NUMBER: 09 INSPECTION TYPE (CIRCLE): (P) AREA OFFICE: 09 INSPECTION DATE: 950602 WELL CLASS: 03

RIG MANAGER: E. May CURRENT DEPTH (m): 2911 PROJECT T.D. (m): 3165 CASING SETTING DEPTH (m): 3165 RIG STATUS: Shut-down

MECHANICAL TESTS

INCREASE ALL TESTS CONDUCTED, INCLUDING LOCATION OF EQUIPMENT AND CONTROLS.		BOP CONTROLS		BOP		TIME TO OPERATE		PRESSURE TEST (psi)			
		NO. ON FLOOR	TYPE	ANNULAR/MCR	RAM	RAM	RAM	LOW	TIME	HIGH	TIME
ACCUMULATOR	RECHARGE PUMP	3	Electric								
MAKE <u>Wagner</u> NO. BOTTLES <u>4</u>	TIME	NO. REMOTE <u>3</u>	TYPE <u>Hyd</u>								
CAPACITY <u>136 L</u>	NO. BOTTLES <u>2</u>	DISTANCE <u>215 m</u>	TYPE <u>Hyd</u>								
DESIGN PRESSURE <u>21101010 psi</u>	CAPACITY <u>84 L</u>	HAND WHEELS <u>✓</u>									
RECHARGE PRESSURE <u>017101010 psi</u>	AVERAGE PRESSURE <u>11571010 psi</u>										
PRESSURE BEFORE <u>010101010 psi</u>											
PRESSURE AFTER											

INSPECTION RESULTS (CODE: significant = 1, caution = 2, satisfactory = 3)

YES NO
 50. RIG APPEARS SATISFACTORY ?

- BOP SYSTEM
- 52. BOP TYPE, RAM SIZE & PRESSURE RATING SATISFACTORY ? *
 - 53. BLEED-OFF & KILL LINES APPEAR SATISFACTORY ? *
 - 54. NON-STEEL HYDRAULIC LINES FIRE SHEATHED ? *
 - 55. DRILL-STRING VALVES READILY ACCESSIBLE ? *
 - 56. EQUIPMENT ADEQUATELY HEATED ? *
 - 57. BOP EQUIPMENT & CONTROLS WORKABLE & PROPERLY CONNECTED ? *
 - 58. DRILL-STRING PRESSURE AVAILABLE AT CHOKE CONTROL ? *
 - 59. MUD-GAS SEPARATOR ADEQUATELY CONNECTED ? *
 - 60. REQUIRED CASING WEAR TESTS BEING PERFORMED ?
- TRAINING & PROCEDURES
- 70. DRILLER HAS P.I.T.S. FIRST LINE CERTIFICATE ? *
 - 71. CREW BOP TRAINING APPEARS SATISFACTORY ? *
 - 72. MUD VOL. MEAS. & HOLE FILL PROCEDURES SATISFACTORY ? *
 - 73. PERSON READILY AVAILABLE WITH P.I.T.S. SECOND LINE CERTIFICATE ? *
 - 74. DRILLER HAS P.I.T.S. WELL SERVICING CERTIFICATE ? *
- RIG OTHER
- 80. WELL TO FLAME-TYPE EQUIPMENT 25 m ?
 - 81. SMOKING RULES BEING OBSERVED 25 m ?
 - 82. DST EQUIPMENT SATISFACTORY ?
 - 83. WARNING SIGNS POSTED IN H₂S AREAS ?
 - 84. BOP PRESSURE TESTS RECORDED & TEST PROCEDURES SATISFACTORY ?
 - 85. DAILY MECHANICAL TESTS RECORDED ?
 - 86. WEEKLY DIESEL ENGINE TESTS RECORDED ?
- ENGINES
- 90. DIESEL ENGINE SHUT-OFFS STOP ALL ENGINES ?
 - 91. ENGINE EXHAUSTS SATISFACTORY ?

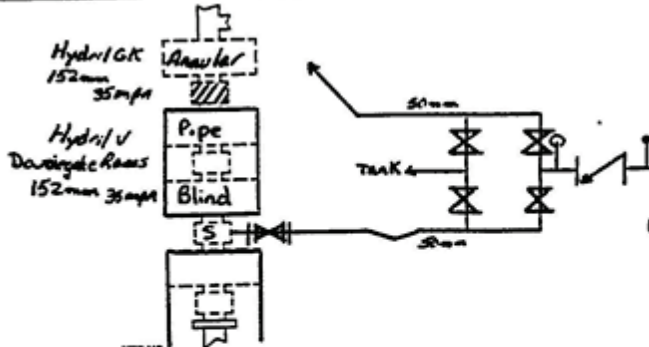

- YES NO
- 100. NON-RIG RELATED ITEMS APPEAR SATISFACTORY ?
- MISCELLANEOUS
- 101. WELL TO END OF FLARE LINE 50 m ?
 - 102. RUBBISH BURN PILE 50 m ?
 - 103. CRUDE OIL STORAGE TANK 50 m ?
 - 104. CONDENSATE RULES BEING OBSERVED ?
 - 105. FLUIDS PROPERLY CONTAINED ?
 - 106. LICENSE POSTED ? NUMBER: _____
 - 107. REQUIRED DEVIATION SURVEYS RUN ?
 - 108. CONTRACTOR & OPERATOR INSPECTIONS RECORDED ?
- LETTER SENT BY AREA OFFICE ?

REMEDIAL ACTION REQUIRED Operations were suspended by on-site supervisor because of a fluid leak in the accumulator. Repairs on-going - unable to check BOPs
Supervisor to call 340-5454 (Red Deer Area Office) when repairs are completed.

Thanks.

Received call on June 3 from J. Strom Accumulator Back in Service
BOPs function tested O.K.

AREA OFFICE: Red Deer BOARD REPRESENTATIVE: S. Rasso CONTRACTOR REPRESENTATIVE: E. May OPERATOR REPRESENTATIVE: J. Strom RIG DOWN TIME: - : -

- S - spool with flanged side outlet connection for bleed-off or kill line.
(spool may have threaded side outlet if wellhead has threaded fittings)

METRIC SYMBOLS

m - metre mm - millimetre kPa - kilopascal kg - kilogram m³ - cubic metre

EQUIPMENT SYMBOLS



Nitrogen Reserve

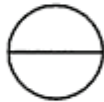

Accumulator



Hydraulic Oil Reservoir



Charge Pump



Flanged Valve



Screwed Valve



Check Valve



Pressure Gauge



Flow Direction



Pop Valve

SCHEDULE 10
REFERRED TO IN SECTION 8.144 OF THE OIL AND GAS CONSERVATION REGULATIONS
SERVICING BLOWOUT PREVENTIONS SYSTEMS - CLASS I
RESERVOIR PRESSURE LESS THAN 5500 kPa AND NO H₂S PRESENT

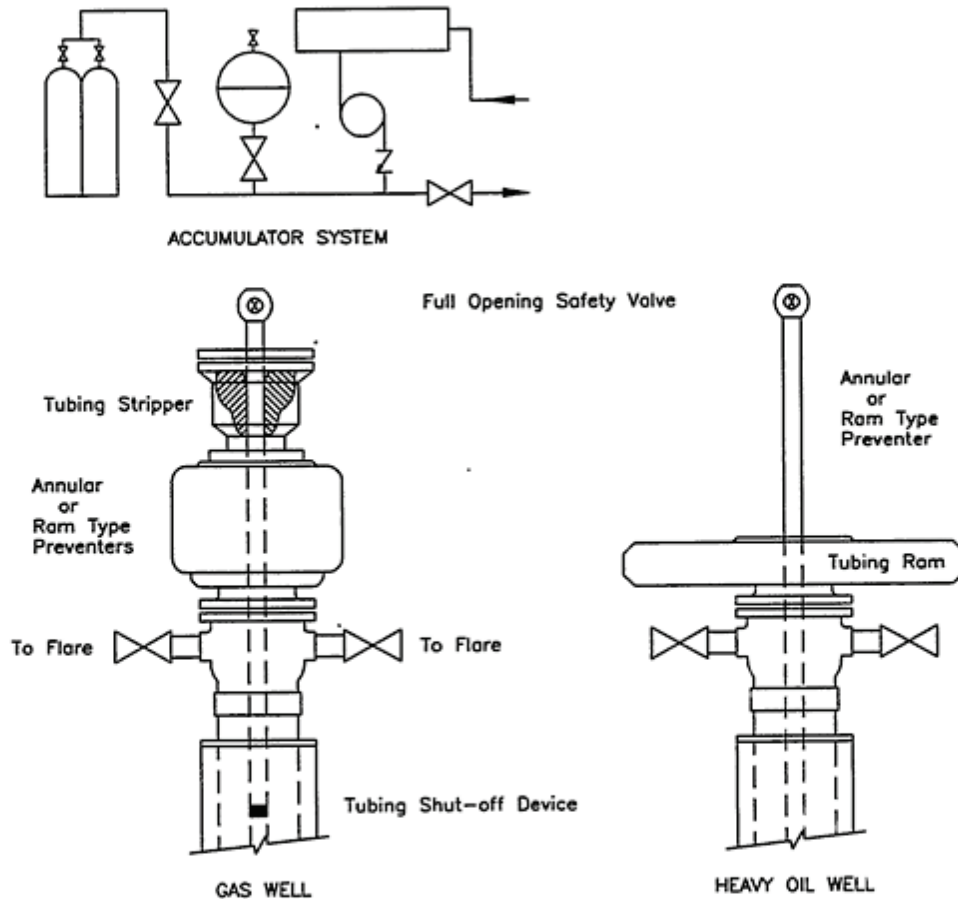

NOTE:

1. Well is not killed.
2. A tubing and blind ram blowout preventer unit may be used in lieu of an annular preventer (position of rams may be interchanged).
3. The tubing stripper may be located below the blowout preventer(s) provided it is an integral part of the wellhead.
4. Two Flare Lines - minimum diameter 50mm, or
 One Flare Line - minimum diameter 75mm, extending 50m from well.

SCHEDULE 10
REFERRED TO IN SECTION 8.144 OF THE OIL AND GAS CONSERVATION REGULATIONS
SERVICING BLOWOUT PREVENTION SYSTEMS - CLASS II
RATING OF PRODUCTION CASING FLANGE IS LESS THAN OR EQUAL TO 21000 kPa
H₂S CONTENT OF THE GAS IS LESS THAN 10 MOLES/KILOMOLE

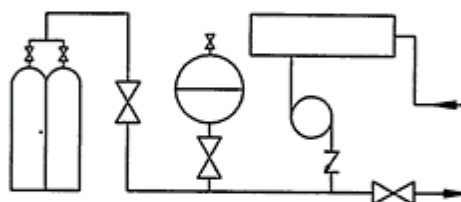

ACCUMULATOR SYSTEM

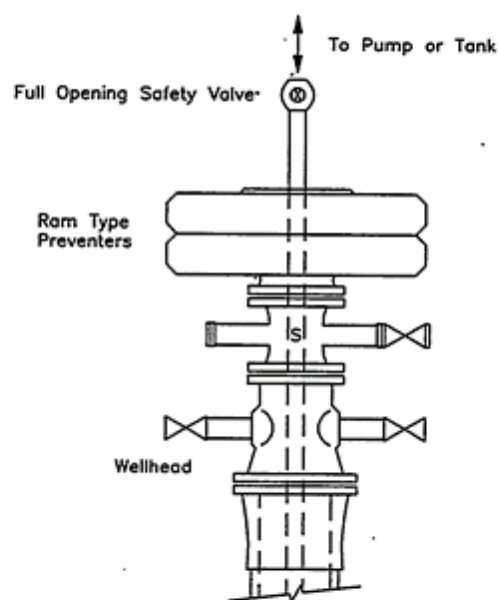

BLOWOUT PREVENTION STACK

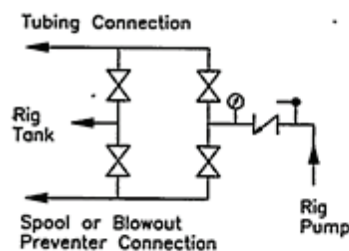

MANIFOLD SYSTEM

NOTE:

1. Pressure rating of preventers is equal to or greater than the production casing flange rating, or the formation pressure, whichever is the lesser.
2. 50mm lines throughout.
3. The positioning of the tubing and blind rams may be interchanged.
4. Spool may have threaded side outlet (and valve) if wellhead has threaded fittings.
5. A flanged blowout preventer port (and valve) below the lowest set of rams may replace spool (valve may be threaded if wellhead has threaded fittings).

SCHEDULE 10

REFERRED TO IN SECTION 8.144 OF THE OIL AND GAS CONSERVATION REGULATIONS
SERVICING BLOWOUT PREVENTION SYSTEMS - CLASS III
RATING OF PRODUCTION CASING FLANGE IS GREATER THAN 21 000 kPa, or
RATING OF PRODUCTION CASING FLANGE IS LESS THAN OR EQUAL TO 21 000 kPa and
H₂S CONTENT OF THE GAS IS EQUAL TO OR GREATER THAN 10 MOLES/KILOMOLE

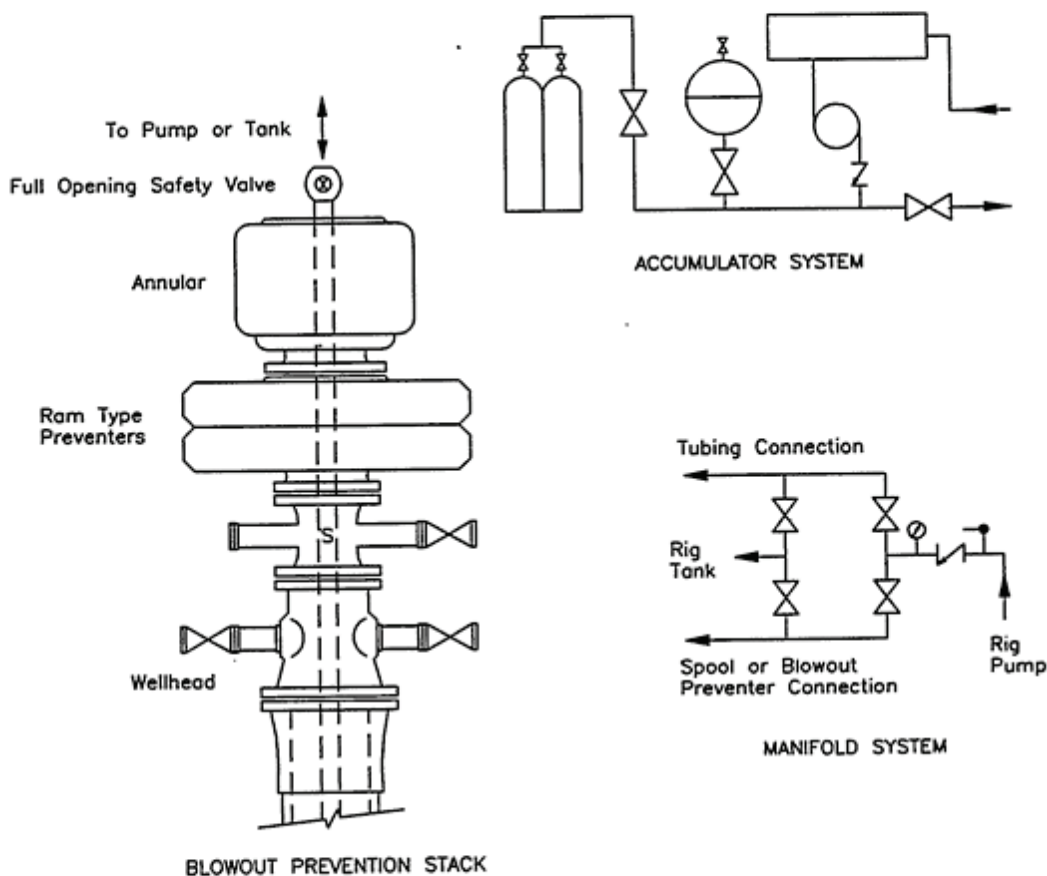

NOTE:

1. Pressure rating of preventers is equal to or greater than the production casing flange rating, or the formation pressure, whichever is the lesser.
2. 50mm lines throughout.
3. The positioning of the tubing and blind rams may be interchanged.
4. Spool may have threaded side outlet (and valve) if wellhead has threaded fittings.
5. A flanged blowout preventer port (and valve) below the lowest set of rams may replace spool (valve may be threaded if wellhead has threaded fittings).

SCHEDULE 11
REFERRED TO IN SECTION 8.148 OF THE OIL AND GAS CONSERVATION REGULATIONS
EQUIPMENT SPACING FOR WELL SERVICING CONVENTIONAL WELLS

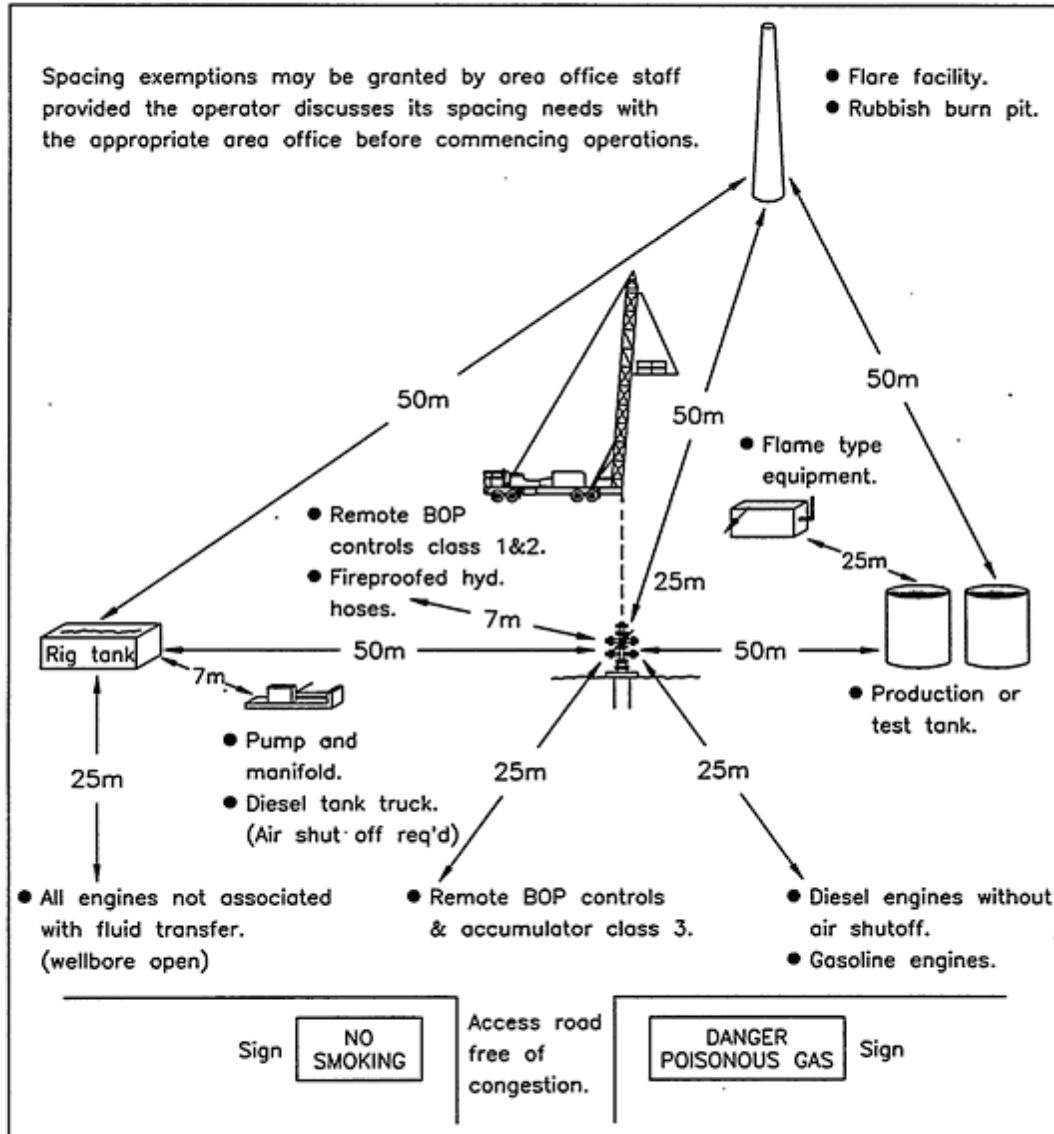

NOTE: The doghouse and light plant must be positioned in accordance with smoking and open flame regulations, and regulations under the Electrical Protection Act.
 All distances shown are minimum distances.

1025: Accumulator Sizing Calculations – Alternate Method

Accumulator Requirements

The accumulator must have sufficient usable fluid available, at a minimum pressure of 8400 kPa, to close all BOPs.

Method Basis

An accumulator's volume of usable* fluid is equal to the volume of hydraulic fluid expelled as the pressure is reduced from the operating pressure to the final pressure. The reduction in pressure causes the gas cap to expand, which expels the hydraulic fluid.

The gas used to pressure the accumulator is assumed to function as an ideal gas.

Method to Determine Usable Fluid Available

1. From the Ideal Gas Law the following pressure (P), volume (V) relations are known:

$$V_{PRE} P_{PRE} = V_{OP} P_{OP} = V_F P_F$$

2. By definition:

$$V_{TOT} = V_{PRE}$$

Therefore:

$$V_{OP} = \frac{V_{TOT} P_{PRE}}{P_{OP}} \quad V_F = \frac{V_{TOT} P_{PRE}}{P_F}$$

3. The hydraulic fluid volume (F) is the total volume minus the volume occupied by the gas:

$$F_{OP} = V_{TOT} - V_{OP} \quad F_F = V_{TOT} - V_F$$

4. The usable fluid (V_{USABLE}) available is the difference between the fluid available at operating conditions and final conditions:

$$\begin{aligned} V_{USABLE} &= F_{OP} - F_F \\ &= V_F - V_{OP} \\ &= \frac{P_{TOT} P_{PRE}}{P_F} - \frac{P_{TOT} P_{PRE}}{P_{OP}} \\ &= V_{TOT} P_{PRE} (1/P_F - 1/P_{OP}) \end{aligned}$$

The usable fluid available is equal to the accumulator volume X the precharge pressure X the difference between the reciprocals of final pressure and the operating pressure.

$$V_{USABLE} = \text{Acc Vol} \times \text{Prech Pres} \times (1/\text{Fin Pres} - 1/\text{Op Pres})$$

* Usable fluid is defined as the amount of fluid stored in the accumulator at a minimum pressure of 8400 kPa.

Calculation Formula

$$V_{\text{USABLE}} = \text{Acc Vol} \times \text{Prech Pres} \times (1/\text{Fin Pres} - 1/\text{Op Pres})$$

Since the Minimum Final* Pressure required is 8400 kPa,

$$V_{\text{USABLE}} = \text{Acc Vol} \times \text{Prech Pres} \times (1.84 \text{ MPa} - 1/\text{Op Pres})$$

Sample Calculation

Rig has:

76.0 litre Accumulator w/
 14.0 MPa Operating Pressure
 7.0 MPa Precharge Pressure
 152.4 mm 21 MPa Shaffer Annular
 152.4 mm 21 MPa Shaffer LWP Pipe Rams
 152.4 mm 21 MPa Shaffer LWP Blind Rams

Step 1

$$\begin{aligned} V_{\text{USABLE}} &= 76 \text{ litres} \times 7.0 \text{ MPa} \times (1/8.4 \text{ MPa} - 1/14.0 \text{ MPa}) \\ &= 76 \text{ litres} \times 7.0 \times 0.048 \\ &= 25.5 \text{ litres} \end{aligned}$$

Step 2

Determine fluid volume needed to close preventers (Appendix 1055).

Vol to close annular	17.3 litres
Vol to close pipe rams	2.1 litres
Vol to close blind rams	2.1 litres
TOTAL VOLUME	21.5 litres

Conclusion

The accumulator is adequate because 25.5 litres of usable fluid is available when only 21.5 litres of fluid is needed to close all BOP components.

1030: Back-Up Nitrogen Calculations – Alternate Method

Nitrogen Requirements

The back-up nitrogen supply must have sufficient usable* volume available, at a minimum pressure of 8400 kPa, to fully close the annular preventer and one set of ram preventers, and open the hydraulic valve.

- If two sets of pipe rams are required, there must be additional usable nitrogen available to close the extra set of rams.

Method Basis

A nitrogen bottle's volume of usable fluid is equal to the volume of gas expelled as the pressure is reduced from the operating pressure to the final pressure. The reduction in pressure causes the gas to expand into the BOP closing system.

Nitrogen is assumed to function as an Ideal Gas.

* If precharge is greater than 8.4 MPa, final pressure must equal precharge pressure.

* Usable is defined as the equivalent litres of stored nitrogen at a minimum pressure of 8400 kPa.

Method to Determine Usable Fluid Available

1. From the Ideal Gas Law the following pressure (P), volume (V) relation is known:

$$P_{OP} V_{OP} = P_F V_F$$

or

$$\frac{V_F}{V_{OP}} = \frac{P_{OP}}{P_F}$$

2. The gas volume at operating conditions (V_{OP}) fills the bottle volume (V_{TOT}):

$$V_{OP} = V_{TOT}$$

The gas volume at final conditions (V_F) fills the bottle and enters the BOP closing system (V_{USE}):

$$V_F = V_{TOT} + V_{USE}$$

$$P_F = 8.4 \text{ MPa}$$

3. Substituting:

$$\frac{V_{TOT} + V_{USE}}{V_{TOT}} = \frac{P_{OP}}{8.4}$$

$$V_{USABLE} = V_{TOT} \frac{P_{OP}}{8.4 \text{ MPa}} - 1$$

Note: If all bottles are the same size, then an average pressure may be used

$$P_{OP} = \frac{P_1 + P_2 + \dots}{\# \text{ } N_2 \text{ bottles}}$$

and the total N_2 bottle must be used.

$$V_{TOT} = V_1 + V_2 + \dots$$

Note: If all bottles are not the same size, then V_{USABLE} must be calculated for each bottle and totalled for the system.

Calculating Formula

$$V_{USABLE} = V_{TOT} \frac{P_{OP}}{8.4 \text{ MPa}} - 1$$

Rig has:

Sample Calculation

- Two - 42-litre N_2 bottles @
- 17.5 MPa and 14.0 MPa
- 152.4-mm 21-MPa Shaffer Annular
- 152.4-mm 21-MPa Shaffer LWP Pipe Rams
- 152.4-mm 21-MPa Shaffer LWP Blind Rams

Step 1Average Pressure of N₂ Bottles.

$$\frac{17.5 \text{ MPa} + 14.0 \text{ MPa}}{2 \text{ bottles}} = 15.75 \text{ MPa}$$

Step 2Total N₂ Volume Available.

$$\begin{aligned} V_{\text{TOT}} &= 42 \text{ litres} + 42 \text{ litres} \\ &= 84 \text{ litres} \end{aligned}$$

Step 3

$$\begin{aligned} V_{\text{USABLE}} &= 84 \text{ litres} \left[\frac{15.75 \text{ MPa}}{8.4 \text{ MPa}} - 1 \right] \\ &= 84 \text{ litres} (0.875) \\ &= 73.5 \text{ litres} \end{aligned}$$

Step 4

Determine fluid volume needed to function preventers (Appendix 1055).

Vol to close annular	17.3 litres
Vol to close pipe rams	2.1 litres
Vol to close blind rams	2.1 litres

TOTAL VOLUME

21.5 litres

ConclusionThe back-up nitrogen supply is adequate since V_{USABLE} is greater than the fluid volume required to activate BOP components.**NITROGEN BOTTLE SIZES AND CAPACITIES**

	(1)	(2)	(3)
*Height (m)	1.52	1.42	1.22
O.D. (mm)	235.00	230.00	180.00
Equivalent volume of liquid (litres)	50.00	42.00	21.00

* Bottle height must be taken from top of valve.

1035: EUB Crew Training Assessment Form

Well Name

Unique Well Identifier							
LE	LS	SC	TWP	RG	WM	EV	

Contractor

Rig No.

Date

TIMES _____

ALERT CALLED ___ ELAPSED ___ / WELL SHUT-IN ___ ELAPSED

MARK APPROPRIATE BOX FOR PROCEDURES APPLICABLE TO SHUT-IN

1. WAS HORN USED TO SOUND ALERT?
2. DID ALL CREW MEMBERS RESPOND TO ALERT?
3. WAS CREW ANTICIPATING A DRILL?
4. DID ON-SITE SUPERVISORS CO-ORDINATE DRILL?
5. DID ON-SITE SUPERVISORS QUESTION CREW ABOUT KICK DETECTION AND SHUT-IN PROCEDURES?
6. WAS WELL SHUT-IN COMPLETED PROPERLY?
7. DID ALL CREW MEMBERS KNOW THEIR POSITIONS AND RESPONSIBILITIES?
8. WAS STABBING VALVE USED?
9. WAS STABBING VALVE ACCESSIBLE AND OPERATIONAL?
10. WAS ROD BOP CLOSING DEVICE ACCESSIBLE AND OPERATIONAL?
11. DID CREW KNOW HOW TO OBTAIN SITP, SICP AND TANK GAIN?
13. WERE PROPER GAUGES AND FITTINGS AVAILABLE TO OBTAIN SITP AND SICP?

YES	NO	
		1.
		2.
		3.
		4.
		5.
		6.
		7.
		8.
		9.
		10.
		11.
		12.

COMMENTS: _____

INSPECTOR _____

CREWS MUST KNOW KICK DETECTION SIGNS AND SHUT-IN PROCEDURES WHEN:

- A. DRILLING/CLEANING TO BOTTOM/CIRCULATION
- B. TRIPPING/TUBING/DRILL PIPE
- C. TUBING DRILL PIPE IS OUT OF WELL
- D. TRIPPING SUCKER RODS.

1040: EUB Crew Procedures Form

* Crew Positions and Duties While Shutting in a Well
 Operation: Drilling/Cleaning to Bottom/Circulating

Step No.	Driller	Derrickman	Floorhand	Floorhand
1.	Calls alert.	To pump control.	To rig floor.	To rig floor.
2.	Stops rotating. Raises kelly or power swivel clear of BOPs	Stops pump. Proceeds to BOP controls		Assists Driller as directed.
3.	Directs Derrickman to, or closes appropriate BOP.	Stands by at BOP control to assist Driller.	Closes annular valve. Installs casing gauge.	
4.	Stays on rig floor and directs crew activities.	Reads and records SITP and SICP until stabilized. Reads and records tank gain (if possible).	Notifies Op. Rep. and Rig Mgr. Returns to rig floor	
ALL CREW MEMBERS - - - - - PREPARE TO KILL WELL				

* The following procedures serve as guidelines only and may vary according to operator preference and the number of rig personnel.

The above procedures are in draft format and are subject to approval by The Well Service Blowout Prevention Examination and Certification Committee.

*** Crew Positions and Duties While Shutting in a Well
Operation: Tripping (Tubing/Drill Pipe)**

Step No.	Driller	Derrickman	Floorhand	Floorhand
1.	Calls alert. Calls down Derrickman.	Comes down derrick.	Rig floor.	Rig floor.
2.	Positions collar just above floor. Sets slips.	Proceeds to BOP controls.	Unlatches elevators. Install stabbing valve and close when directed by Driller	Assists Floorhand.
3.	Directs Derrickman to, or closes appropriate BOP.	Stands by at BOP control to assist Driller.	Closes annular valve. Installs casing gauge.	
4.	Picks up circulating equipment.	Fill circulating lines and stops pump.	Picks up and connects circulating equipment. Opens stabbing valve.	Returns to rig floor. Assists in make up of circulating equipment.
6.	Stays on rig floor and directs crew activities.	Reads and records SITP and SICP until stabilized. Reads and records tank gain (if possible).	Notifies Op. Rep. and Rig. Mgr. Returns to rig floor.	Stands by on rig floor.
ALL CREW MEMBERS - - - - - PREPARE TO KILL WELL				

* The following procedures serve as guidelines only and may vary according to operator preference and the number of rig personnel.

The above procedures are in draft format and are subject to approval by The Well Service Blowout Prevention Examination and Certification Committee.

* **Crew Positions and Duties While Shutting in a Well**
Operation: Tubing/Drill Pipe Out of Hole

Step No.	Driller	Derrickman	Floorhand	Floorhand
1.	Calls alert.	Proceeds to BOP controls.	To rig floor	To rig floor
2.	Directs Derrickman to, or closes blind rams.	Stands by at BOP control to assist Driller.	Closes annular valve. Installs casing gauge. Returns to rig floor.	Assists Driller as directed.
3.	Stays on rig floor and directs crew activities.	Reads and records SICP until stabilized. Reads and records tank gain (if possible).	Notifies Op. Rep. and Rig Mgr. Returns to rig floor.	
ALL CREW MEMBERS - - - - PREPARE TO KILL WELL				

* The following procedures serve as guidelines only and may vary according to operator preference and the number of rig personnel.

The above procedures are in draft format and are subject to approval by The Well Service Blowout Prevention Examination and Certification Committee.

CREW PROCEDURES FORM

*** Crew Positions and Duties While Shutting in a Well
Operation: Tripping (Sucker Rods)**

Step No.	Driller	Derrickman	Floorhand	Floorhand
1.	Calls alert. Calls down Derrickman.	Comes down from derrick.	Rig floor.	Rig floor
2.	Positions rod elevator.	Stands by to assist Driller.	Unlatches rod hook, if required.	
3.	Stays on rig floor and directs crew activities.		Closes rod BOP.	Closes flow line valve to rig tank.
4.			Installs pressure gauge on flow tee.	Returns to rig floor.
5.		Reads and records SITP and SICP until stabilized. Reads and records tank gain (if possible).	Notifies Op. Rep. and Rig Mgr. Returns to rig floor.	
ALL CREW MEMBERS - - - - - PREPARE TO KILL WELL				

* The following procedures serve as guidelines only and may vary according to operator preference and the number of rig personnel.

The above procedures are in draft format and are subject to approval by The Well Service Blowout Prevention Examination and Certification Committee.

Inspection No. Inspection Item and Deficiency

52 BOP Type, Ram Size, & Pressure Rating

1. Using inadequate preventer
2. Improper pipe ram sizing
3. BOP pressure rating low
4. BOP stack arrangement does not conform to requirements (annular not provided)
5. Spool improper pressure rating
6. Tubing stripper not installed or not operating properly (Class I gas wells only)
7. Tubing plug or other suitable shut-off device not installed in tubing string during tripping operations (Class I gas wells only)
8. Wireline annular preventer not in use (conventional annular preventer not in service)
9. Three-year shop servicing not conducted
10. BOP stack arrangement does not conform to requirements (however, all components are present)
11. BOP pressure rating not detectable

53 Bleed Off & Kill Lines

1. Pressure gauge at manifold inaccurate (e.g. out of calibration or range too large and no suitable back-up)
2. Check valve in kill line in backwards
3. Kill line or bleed-off line or manifold improper pressure rating
4. Shock hose in kill line or bleed-off line improper pressure rating
5. Kill line and/or bleed-off line not properly secured
6. Casing gauge inaccurate (e.g. out of calibration or range too large and no suitable back-up)
7. Manifold valves difficult to operate, need lubrication/repair, or washed out

8. Valve handles missing on kill line or bleed-off line or manifold (no alternate handle provided)
9. Manifold design improper - check valve or valves location incorrect
10. Kill line or bleed-off line improperly positioned within BOP stack
11. Kill line or bleed-off line or manifold improper size
12. Bolts missing from bleed-off or kill line flanges
13. End of flare line does not terminate in flare pit (class I)
14. Bleed-off line disconnected from wellhead
15. Kill line and/or bleed-off line not connected to rig tank or manifold
16. Spool or flanged BOP port not used for bleed-off or kill-line connection (Classes II, IIA and III)
17. Improper spool used for bleed-off or kill-line connection on Class II or III well (spool has threaded outlets whereas wellhead has flanged equipment)

54 Non-Steel Hydraulic Lines Fire Sheathed

1. Hydraulic hoses inadequately fire sheathed or fire sheathing damaged

55 Drill-String Valves Readily Accessible

1. Stabbing valve not accessible or not operable
2. Stabbing valve closing handle not on location or inaccessible
3. Work string cross-over sub not available or accessible
4. Stabbing valve in closed position
5. Stabbing valve not full opening
6. Poor maintenance of valve threads on stabbing valve or work string cross-over sub
7. Hanger cap on stabbing valve not full opening
8. Carrying handles/hanger cap not provided

56 Equipment Adequately Heated

1. BOPs inadequately heated
2. Bleed-off and/or kill-line valves iced up
3. Ice plug in bleed-off and/or kill line
4. Stabbing valve not kept in ice-free environment during cold weather conditions

57 BOP Equipment & Controls Workable & Properly Connected

1. Accumulator has insufficient usable fluid available, at a minimum pressure of 8400 kPa, to close all BOP components (sizing calculations performed)
2. Accumulator not connected to hydraulic system
3. Accumulator gauge inaccurate or unavailable
4. Full BOP controls not provided at or near Driller's station
5. Remote BOP controls inadequate or controls not provided
6. Nitrogen bottles not provided
7. Nitrogen bottles not connected or improperly connected

8. Gauge and/or fittings not available for taking pressure of nitrogen bottles
9. Nitrogen bottle gauge inaccurate
10. Nitrogen bottle volume low (insufficient usable fluid available—sizing calculations performed)
11. Accumulator pump failed to recharge accumulator
12. Annular or ram preventer seals leaking
13. Hydraulic hoses improper pressure rating
14. BOP control functions not clearly marked
15. Fluid leak in hydraulic system (BOPs will not function)
16. Fluid by-passing through BOP controls (BOPs will not function) or pressure dropped below 8400 kPa after function test with pump off. Bypass allows loss of pressure.
17. Closing devices (cranks) not available for rod preventer
18. BOPs failed to operate from remote position
19. BOPs failed to operate from Driller's position
20. BOPs not installed on well
21. Manual BOP closing device not available or incorrectly sized
22. Accumulator pump failed to recharge accumulator within 5 minutes
23. Fittings not available to obtain accumulator precharge
24. Accumulator improperly connected (check valve location does not allow for accumulator recharge pump change)
25. Hydraulic hoses not protected from damage (outer protective coating either damaged or missing)
26. Remote controls located within 7 m of wellbore (Classes I, II and IIA) or within 25 m (Class III)
27. Fluid leak in hydraulic system (BOPs still function)
28. Fluid by-passing through BOP controls (BOPs still function) and no pressure loss occurring on system
29. Annular or ram preventers failed to close within regulation times

30. Bolts missing from BOP or wellhead to the wellhead flange during operations
31. Accumulator bottles cannot be isolated to prevent back-up nitrogen loss into system

71 Crew BOP Training

1. Crew training inadequate
2. Crew drills not being performed
3. Rig horn inoperable or not in place for sounding crew alert (crew did not respond to alternative alert)
4. Crew BOP drills not recorded in tour reports (prior to commencement of operations or after BOPs installed)
5. Rig horn inoperable or not in place for sounding crew alert (crew responded to alternative alert)

72 Fluid Measurements & Hole-Filling Procedures

1. Rig pump and/or tank not on location

74 Driller Has Valid Well Service Control Certificate issued by ESC, the IWCF, the IADC, or an equivalent organization

1. Driller does not have a valid well service control certificate
2. The driller's certificate is from a different organization, but it was not deemed equivalent by the AER

80 Well to Flame-Type Equipment

1. Flame-type equipment operating within 25 m of wellbore (welder, steamer)

81 Smoking Rules Being Observed

1. Member of rig crew or other individual observed smoking within 25 m of wellbore
2. Evidence of smoking within 25 m of wellbore

82 DST Equipment

1. Remote controlled master valve on testing head not provided

2. Remote controlled master valve on testing head not operating
3. Reverse circulating sub not installed in test string

83 Warning Signs Posted in H₂S Areas

1. Warning sign not posted
2. Warning sign illegible
3. Warning sign posted on known sweet well

84 BOP Pressure Tests Recorded & Test Procedures Satisfactory

1. BOP components not pressure tested
2. Stabbing valve would not pressure test (after operations in progress)
3. Pressure test not recorded in tour reports
4. Incomplete pressure test data recorded in tour reports
5. Low-pressure test not conducted
6. Low-pressure test not conducted prior to high-pressure test
7. Improper test pressure used
8. Pressure testing medium not low viscosity fluid
9. Well control equipment testing times less than 10 minutes

85 Daily Mechanical Tests Recorded

1. Daily BOP mechanical tests not completed
2. Daily mechanical tests not recorded
3. Description of mechanical tests conducted incomplete

86 Weekly Diesel Engine Tests Recorded

1. Diesel engine shut-off test not conducted prior to commencing operations
2. Diesel engine shut-off test, conducted prior to commencing operations, not recorded
3. Weekly diesel engine shut-off test not conducted
4. Weekly diesel engine shut-off test not recorded

90 Diesel Engine Shut-Offs

1. Diesel engine shut-off did not operate
2. Air supply not connected to diesel engine shut-off
3. Diesel engine not equipped with shut-off

91 Engine Exhausts

1. Engine exhausts in need of repair
2. Engine exhausts not directed away from wellbore

101 End of Flare Line

1. Flare line not 50 m from wellbore
2. Flare pit improperly constructed

102 Rubbish Burn Pile

1. Camp and rig combustible debris not being disposed of properly as required in Appendix 1100
2. Information not readily available to show proper characterization of wastes generated on site (Dangerous/Non-dangerous)(e.g. CAODC wall chart)
3. Wastes generated on site not properly stored (i.e. secondary containment)
4. Waste material generated on site disposed of at a facility not approved to handle that specific waste
5. Records not available showing source, volume and final disposition of waste

103 Crude Oil Storage Tank

1. Crude oil storage tank located within 50 m of wellbore
2. Service rig tank located within 7 m of rig pump

104 Condensate Rules Being Observed

1. Open tank used for storing or gauging or measuring the pumping rate
2. Minimum distance of 50 m not maintained between the wellhead and storage tank
3. Positive shut-off valve not installed between pump and wellhead

4. Check valve not installed between pump and wellhead
5. Surface lines not pressure tested or test pressure inadequate
6. Approval to use condensate for fracturing not obtained from Calgary office

105 Fluids Properly Contained

1. Sump leaking
2. Fluids around rig substructure not directed to sump
3. Transfer of drilling fluids to remote sump unsatisfactory
4. Workover or wellbore fluids spilled on or off lease
5. Chemicals, mud additives, fuel, or other materials spilled on or off lease

106 Licence Posted

1. Well licence not at lease (well re-entry/not original licensee)
2. Well licence not posted (well re-entry/not original licensee)

108

1. Contractor and operator inspections not recorded
2. Contractor and operator detailed inspections NOT conducted
3. Contractor and operator daily inspections NOT conducted

1055: BOP Fluid Volumes

Acknowledgement

The following tables were prepared from data supplied by the various BOP manufacturers listed in this section. The co operation of these companies is greatly appreciated.

Ram-type Blowout Preventer

MODEL OR TYPE	BOP SIZE mm	WORKING PRESSURE MAXIMUM kPa	VERTICAL BORE Mm	HYDRAULIC OPERATOR kPa	LITRES TO CLOSE	LITRES TO OPEN	CLOSE RATIO	OPEN RATIO
			Bowen Tools					
51922	63.5S	42 000	63.5	5 378	0.6	0.6	7.9	
51923	63.5S	70 000	63.5	8 963	0.7	0.7	7.9	
51924	63.5T	34 000	63.5	4 771	1.4	1.1	7.9	
60701	63.5T	69 000	63.5	6 902	1.6	1.3	7.9	
50460	65.1S	104 000	65.1	6 895	1.1	1.1	8.18	
51926	76.2S	34 000	76.2	2 544	1.1	0.8	13.2	
51927	76.2S	69 000	76.2	5 088	1.1	0.8	13.2	
51928	76.2T	34 000	76.2	2 544	2.0	1.9	13.2	
51929	76.2T	69 000	76.2	5 088	2.0	1.9	13.2	
61040	101.6S	34 000	101.6	3 827	3.4	3.1	15.3	
61044	101.6S	69 000	101.6	7 653	3.4	3.1	15.3	
61048	101.6T	34 000	101.6	3 827	4.5	6.1	15.3	
61050	101.6T	69 000	101.6	7 653	4.5	6.1	15.3	
47034	103.2S	69 000	103.2	6 895	1.6	1.3	13.6	
60467	103.2S	104 000	103.2	20 684	1.6	1.3	13.6	
61053	114.3S	21 000	114.3	2 551	3.4	3.1	15.3	
61055	114.3S	69 000	114.3	7 653	3.4	3.1	15.3	
61057	114.3T	34 000	114.3	3 827	6.9	6.2	15.3	
61060	114.3T	69 000	114.3	7 653	6.9	6.2	15.3	
51938	139.7S	21 000	139.7	1 655	5.7	5.2	20.8	
63642	179.4S	69 000	179.4	6 205	2.8	2.8	10.9	

Ram-type Blowout Preventer

MODEL OR TYPE	BOP SIZE mm	WORKING PRESSURE MAXIMUM kPa	VERTICAL BORE mm	HYDRAULIC OPERATOR kPa	LITRES TO CLOSE	LITRES TO OPEN	CLOSE RATIO	OPEN RATIO
			Cameron Iron Works					
U	152.4	21 000	179.4	10 500/21 000	5.0	4.8	7:1	2.30:1
U	152.4	34 000	179.4	10 500/21 000	5.0	4.8	7:1	2.30:1
U	179.4	69 000	179.4	10 500/21 000	5.0	4.8	7:1	2.30:1
U	179.4	104 000	179.4	10 500/21 000	5.0	4.8	7:1	2.30:1
U	254.0	21 000	279.4	10 500/21 000	12.7	12.1	7:1	2.30:1
U	254.0	34 000	279.4	10 500/21 000	12.7	12.1	7:1	2.30:1
U	279.4	69 000	279.4	10 500/21 000	12.7	12.1	7:1	2.30:1
U	279.4	104 000	279.4	10 500/21 000	12.7	12.1	7:1	2.30:1
QRC	152.4	21 000	179.4	10 500/34 000	3.1	3.6	7.75:1	1.50:1
QRC	152.4	34 000	179.4	10 500/34 000	3.1	3.6	7.75:1	1.50:1
QRC	203.2	21 000	228.6	10 500/34 000	8.9	10.2	9.05:1	1.83:1
QRC	203.2	34 000	228.6	10 500/34 000	8.9	10.2	9.05:1	1.83:1
QRC	254.0	21 000	279.4	10 500/34 000	10.5	12.0	9.05:1	1.21:1
QRC	254.0	34 000	279.4	10 500/34 000	10.5	12.0	9.05:1	1.21:1
QRC	304.8	21 000	346.1	10 500/34 000	16.7	19.3	8.64:1	1.07:1
Type	152.4	21 000	179.4	1 725/10 500	15.0	13.0	V	4.90:1
F	152.4	34 000	179.4	1 725/10 500	15.0	13.0	A	4.90:1
With	177.8	69 000	179.4	1 725/10 500	15.0	13.0	R	4.90:1
Type	177.8	104 000	179.4	1 725/10 500	15.0	13.0	I	4.90:13.44:1
L	203.2	21 000	228.6	1 725/10 500	25.9	23.4	A	
Oper							B	
							L	
							E	

Ram-type Blowout Preventer

MODEL OR TYPE	BOP SIZE mm	WORKING PRESSURE MAXIMUM kPa	VERTICAL BORE mm	HYDRAULIC OPERATOR kPa	LITRES TO CLOSE	LITRES TO OPEN	CLOSE RATIO	OPEN RATIO
			Cameron Iron Works					
Type	203.2	34 000	228.6	1 725/10 500	25.9	23.4	V	3.44:1
F	254.0	21 000	279.4	1 725/10 500	25.9	23.4	A	3.44:1
With	254.0	34 000	279.4	1 725/10 500	25.9	23.4	R	3.44:1
Type	279.4	69 000	279.4	1 725/10 500	25.9	23.4	I	3.44:1
L	304.8	21 000	346.1	1 725/10 500	39.0	35.5	A	2.30:1
Oper							B L E	
Type	152.4	21 000	179.4	6 900/34 000	2.0	4.0		1.50:1
F	152.4	34 000	179.4	6 900/34 000	2.0	4.0	V	1.50:1
With	177.8	69 000	179.4	6 900/34 000	2.0	4.0	A	1.50:1
Type	177.8	104 000	179.4	6 900/34 000	2.0	4.0	R	1.50:1
H	203.2	21 000	228.6	6 900/34 000	3.4	6.8	I	10:1
Oper	203.2	34 000	228.6	6 900/34 000	3.4	6.8	A	10:1
	254.0	21 000	279.4	6 900/34 000	3.4	6.8	B	10:1
	254.0	34 000	279.4	6 900/34 000	3.4	6.8	L	10:1
	279.4	69 000	279.4	6 900/34 000	3.4	6.8	E	10:1
	304.8	21 000	346.1	6 900/34 000	5.6	10.2		2.13:1

Ram-type Blowout Preventer

MODEL OR TYPE	BOP SIZE mm	WORKING PRESSURE MAXIMUM kPa	VERTICAL BORE mm	HYDRAULIC OPERATOR kPa	LITRES TO CLOSE	LITRES TO OPEN	CLOSE RATIO	OPEN RATIO
			Cameron Iron Works					
SS	152.4	21 000	179.4	10 500/34 000	3.0	2.6	3.8:1	10:1
SS	152.4	34 000	179.4	10 500/34 000	3.0	2.6	3.8:1	10:1
SS	203.2	21 000	228.6	10 500/34 000	5.7	4.9	3.8:1	10:1
SS	203.2	34 000	228.6	10 500/34 000	5.7	4.9	3.9:1	10:1
SS	254.0	21 000	279.4	10 500/34 000	5.7	4.9	3.9:1	10:1
SS	254.0	34 000	279.4	10 500/34 000	5.7	4.9	3.9:1	10:1
SS	304.8	21 000	346.1	10 500/34 000	11.0	9.5	3.7:1	10:1
Type	152.4	21 000	179.4	3 500/10 500	5.7	8.7	V	4.50:1
F	152.4	34 000	179.4	3 500/10 500	5.7	8.7	A	4.50:1
With	177.8	69 000	179.4	3 500/10 500	5.7	8.7	R	4.50:1
Type	177.8	104 000	179.4	3 500/10 500	5.7	8.7	I	4.50:1
W2	203.2	21 000	228.6	3 500/10 500	10.6	14.0	A	2.50:1
Oper	203.2	34 000	228.6	3 500/10 500	10.6	14.0	B	2.50:1
	254.0	21 000	279.4	3 500/10 500	10.6	14.0	L	2.50:1
	254.0	34 000	279.4	3 500/10 500	10.6	14.0	E	2.50:1

Ram-type Blowout Preventer

MODEL OR TYPE	BOP SIZE mm	WORKING PRESSURE MAXIMUM kPa	VERTICAL BORE mm	HYDRAULIC OPERATOR kPa	LITRES TO CLOSE	LITRES TO OPEN	CLOSE RATIO	OPEN RATIO
			Cameron Iron Works					
Type	152.4	21 000	179.4	3 500/10 500	8.7	11.5		
F	152.4	34 000	179.4	3 500/10 500	8.7	11.5	V	
With	177.8	69 000	179.4	3 500/10 500	8.7	11.5	A	
Type	177.8	104 000	179.4	3 500/10 500	8.7	11.5	R	
W	203.2	21 000	228.6	3 500/10 500	14.0	17.4	I	
Oper	203.2	34 000	228.6	3 500/10 500	14.0	17.4	A	
	254.0	21 000	279.4	3 500/10 500	14.0	17.4	B	
	254.0	34 000	279.4	3 500/10 500	14.0	17.4	L	
	279.4	69 000	279.4	3 500/10 500	14.0	17.4	E	
	304.8	21 000	346.1	3 500/10 500	25.7	30.7		

Ram-type Blowout Preventer

MODEL OR TYPE	BOP SIZE mm	WORKING PRESSURE MAXIMUM kPa	VERTICAL BORE mm		HYDRAULIC OPERATOR kPa	LITRES TO CLOSE	LITRES TO OPEN	CLOSE RATIO	OPEN RATIO
			Dresser Ome (Guiberson)						
Type H	152.4	21 000	187.3		14 000	4.2	3.6	6.50:1	1:1
Hyd Cyl	203.2	14 000	230.2		14 000	4.2	3.6	6.50:1	1:1
			Dreco and Griffith Oil Tool						
1531	179.4	21 000	177.8	6 825		2.0	1.5		
1101	179.4	34 500	177.8	9 100		2.6	1.9		
			Hydril Company						
V	152.4	21 000	179.4	5 171		5.7	4.9	5.32:1	
V	152.4	34 000	179.4	8 101		5.7	4.9	5.32:1	
V	254.0	21 000	279.4	3 792		12.5	12.1	6.00:1	
V	254.0	34 000	279.4	5 861		12.5	12.1	6.00:1	
X	279.4	69 000	279.4	7 239		48.8	44.7	10.56:1	
V	304.8	21 000	346.1	4 826		22.3	18.5	5.20:1	

Ram-type Blowout Preventer

MODEL OR TYPE	BOP SIZE mm	WORKING PRESSURE MAXIMUM kPa	VERTICAL BORE mm	HYDRAULIC OPERATOR kPa	LITRES TO CLOSE	LITRES TO OPEN	CLOSE RATIO	OPEN RATIO
			Rucker Shaffer					
Types B&E	152.4	21 000	179.4	10 500/21 000	10.4	8.7	6.00:1	2.57:1
	152.4	34 000	179.4	10 500/21 000	10.4	8.7	6.00:1	2.57:1
	203.2	21 000	228.6	10 500/21 000	10.4	8.7	6.00:1	1.89:1
	203.2254.0	34 000	228.6	10 500/21 000	10.4	8.7	6.00:1	1.89:1
	0	21 000	279.4	10 500/21 000	12.3	10.2	6.00:1	1.51:1
	254.0	34 000	279.4	10 500/21 000	12.3	10.2	6.00:1	1.35:1
	304.8	21 000	346.1	10 500/21 000	13.4	11.0	6.00:1	1.14:1
LWS	103.2	69 000	103.2	10 500/21 000	2.2	1.8	8.45:1	4.74:1
With	152.4	21 000	179.4	10 500/21 000	4.7	3.8	4.44:1	1.82:1
Locking	152.4	34 000	179.4	10 500/21 000	4.7	3.8	4.45:1	1.82:1
Manual	179.4	69 000	179.4	10 500/21 000	24.0	22.3	10.63:1	19.40:1
Screw	179.4	104 000	179.4	10 500/21 000	24.0	22.3	10.63:1	19.40:1
	203.2	21 000	228.6	10 500/21 000	9.8	8.6	5.58:1	3.00:1
	203.2	34 000	228.6	10 500/21 000	9.8	8.6	5.58:1	3.00:1
	228.6	69 000	228.1	10 500/21 000	9.2	8.1	5.58:1	1.69:1
	254.0	21 000	279.4	10 500/21 000	6.6	5.5	4.45:1	1.16:1
	254.0	34 000	279.4	10 500/21 000	11.3	9.9	5.58:1	2.10:1
	279.4	69 000	279.4	10 500/21 000	13.7	12.5	7.83:1	2.20:1
	304.8	21 000	346.1	10 500/21 000	12.7	11.2	5.58:1	1.75:1

Ram-type Blowout Preventer

MODEL OR TYPE	BOP SIZE mm	WORKING PRESSURE MAXIMUM kPa	VERTICAL BORE mm	HYDRAULIC OPERATOR kPa	LITRES TO CLOSE	LITRES TO OPEN	CLOSE RATIO	OPEN RATIO
			Rucker Shaffer					
LWS Posi- Lock	179.4	104 000	179.4	10 500/21 000	27.4	25.0	10.85:1	19.44:1
	254.0	34 000	279.4	10 500/21 000	18.0	15.8	8.16:1	3.07:1
	254.0	34 000	279.4	10 500/21 000	35.2	32.1	10.85:1	7.82:1
	279.4	69 000	279.4	10 500/21 000	15.9	14.0	8.16:1	2.21:1
	279.4	69 000	279.4	10 500/21 000	31.2	28.4	10.85:1	6.24:1
	304.8	21 000	346.1	10 500/21 000	20.2	17.8	8.16:1	2.56:1
	304.8	21 000	346.1	10 500/21 000	40.0	36.4	10.85:1	6.25:1
LWP	152.4	21 000	179.4	10 500/21 000	2.1	1.9	4.00:1	1.81:1
	203.2	21 000	228.6	10 500/21 000	2.9	2.6	4.00:1	2.50:1
Sen- tinel	179.4	21 000	179.4	10 500	2.6	2.1	4.00:1	2.50:1
			Well Site Specialists Incorporated WSI					
Duke	179.4	21 000	179.4	10 500	2.7	2.2	4.20:1	

Bag-type (or Annular) Preventers, Diverters, Strippers

MODEL OR TYPE	BOP SIZE mm	WORKING PRESSURE MAXIMUM kPa	VERTICAL BORE mm	HYDRAULIC OPERATOR kPa	LITRES TO CLOSE	LITRES TO OPEN	PACK OFF OPEN HOLE MINIMUM kPa
			Cameron Iron Works				
A	152.4	34 000	179.4	10 500	8.3	7.2	NA
A	152.4	69 000	179.4	10 500	15.1	11.7	NA
A	279.4	34 000	279.4	10 500	29.5	24.6	NA
A	279.4	69 000	279.4	10 500	45.8	39.7	NA
D	179.4	34 000	179.4	10 500/21 000	6.4	5.3	NA
D	179.4	69 000	179.4	10 500/21 000	11.1	9.7	NA
D	179.4	104 000	179.4	10 500/21 000	26.3	23.2	NA
D	179.4	138 000	179.4	10 500/21 000	31.7	28.6	NA
D	279.4	21 000	279.4	10 500/21 000	21.4	17.8	NA
D	279.4	34 000	279.4	10 500/21 000	21.4	17.8	NA
D	279.4	69 000	279.4	10 500/21 000	38.4	34.3	NA
			Griffith Oil Tool				
1100	179.4	21 000	179.4	10 500/21 000	14.8	12.7	
1100	179.4	34 500	179.4	10 500/21 000	14.8	12.7	

NOTE: 21 000 kPa closing pressure may be applied safely to the Cameron “D” and Griffith annular preventers to effect a faster closing time; however, this is not a requirement.

Bag-type (or Annular) Preventers, Diverters, Strippers

MODEL OR TYPE	BOP SIZE mm	WORKING PRESSURE MAXIMUM kPa	VERTICAL BORE mm	HYDRAULIC OPERATOR kPa	LITRES TO CLOSE	LITRES TO OPEN	PACK OFF OPEN HOLE MINIMUM kPa
			Hydril Company				
GK	152.4	21 000	179.4	10 500	10.8	8.5	6 895
GK	152.4	34 000	179.4	10 500	14.6	12.5	6 895
GK	203.2	21 000	227.0	10 500	16.4	12.9	7 240
GK	203.2	34 000	227.0	10 500	25.9	22.0	7 930
GK	254.0	21 000	279.4	10 500	28.1	21.0	7 930
GK	254.0	34 000	279.4	10 500	37.1	30.2	7 930
GK	304.8	21 000	346.1	10 500	43.0	33.8	7 930
MSP	152.4	14 000	179.4	10 500	10.8	7.5	6 895
MSP	203.2	14 000	227	10 500	17.3	11.2	7 240
MSP	254.0	14 000	279.4	10 500	28.1	19.8	7 930

Bag-type (or Annular) Preventers, Diverters, Strippers

MODEL OR TYPE	BOP SIZE mm	WORKING PRESSURE MAXIMUM kPa	VERTICAL BORE mm	HYDRAULIC OPERATOR kPa	LITRES TO CLOSE	LITRES TO OPEN	PACK OFF OPEN HOLE MINIMUM kPa
			Hydril Company				
K	76.2	21 000	76.2	21 000	0.76	NA	V
K	101.6	21 000	101.6	21 000	3.0	NA	A
K	177.8	21 000	179.4	21 000	6.1	NA	R
K	219.1	21 000	200.0	21 000	12.9	NA	I
K	244.5	21 000	225.4	21 000	21.6	NA	A
K	273.1	21 000	254.0	21 000	28.8	NA	B
K	298.5	21 000	276.2	21 000	30.7	NA	L
K	298.5	21 000	282.6	21 000	39.0	NA	E
Torus	152.4	21 000	179.4	21 000 21 000 21 000 21 000	16.3	NA	V
Torus	152.4	21 000	179.4		16.3	NA	A
Torus	203.2	21 000	228.6		30.7	NA	R
Torus	203.2	42 000	228.6		30.7	NA	I B L E

Bag-type (or Annular) Preventers, Diverters, Strippers

MODEL OR TYPE	BOP SIZE mm	WORKING PRESSURE MAXIMUM kPa	VERTICAL BORE mm	HYDRAULIC OPERATOR kPa	LITRES TO CLOSE	LITRES TO OPEN	PACK OFF OPEN HOLE MINIMUM kPa
			Hydril Company				
Spher BOP	103.1	69 000	103.1	10 500	7.8	6.3	V
Spher BOP	152.4	21 000	179.4	10 500	17.3	12.2	A
Spher BOP	152.4	34 000	179.4	10 500	17.3	12.2	R
Spher BOP	203.2	21 000	228.6	10 500	27.4	19.0	I
Spher BOP	203.2	34 000	228.6	10 500	41.8	33.0	A
Spher BOP	254.0	21 000	279.4	10 500	41.6	25.7	B
Spher BOP	254.0	34 000	279.4	10 500	70.7	55.2	L
Spher BOP	304.8	21 000	346.1	10 500	89.0	55.5	E

Cameron Iron Works

MODEL OR TYPE	LINE SIZE mm	MAXIMUM WORKING PRESSURE kPa	BORE SIZE mm	HYDRAULIC OPERATION MAXIMUM kPa	LITRES TO CLOSE	LITRES TO OPEN
HCR	101.6	21 000	101.6		2.3	2.0
HCR	101.6	34 000	101.6	10 500	2.3	2.0
HCR	152.4	21 000	177.8	10 500	8.5	7.4
HCR	152.4	34 000	177.8	10 500 10 500	8.5	7.4
F	50.8	6 600/21 000	46.1	10 500/34 000	0.4	0.4
F	50.8	34 000/104 000	46.1	10 500/34 000	0.6	0.6
F	50.8	6 600/21 000	52.4	10 500/34 000	0.4	0.4
F	50.8	34 000/104 000	52.4	10 500/34 000	0.6	0.6
F	63.5	6 600/69 000	65.1	10 500/34 000	0.8	0.8
F	63.5	104 000	65.1	10 500/34 000	1.5	1.5
F	76.2	6 600/14 000	79.4	10 500/34 000	0.6	0.6
F	76.2	21 000/34 000	79.4	10 500/34 000	0.9	0.9
F	76.2	69 000	79.4	10 500/34 000	1.0	1.0
F	76.2	104 000	79.4	10 500/34 000	1.9	1.9
F	101.6	14 000/34 000	104.8	10 500/34 000	1.1	1.1
F	101.6	69 000	104.8	10 500/34 000	2.2	2.2
F	152.4	14 000/34 000	155.6	10 500/34 000	3.2	3.2

Cameron Iron Works

MODEL OR TYPE	LINE SIZE mm	MAXIMUM WORKING PRESSURE kPa	BORE SIZE mm	HYDRAULIC OPERATION MAXIMUM kPa	LITRES TO CLOSE	LITRES TO OPEN
DV	101.6	21 000	101.6	10 500	3.0	4.2
DV	101.6	34 000	101.6	10 500	3.0	4.2
DV	152.4	21 000	177.8	10 500	7.9	13.6
DV	203.2	21 000	228.6	10 500	9.1	21.2
DV	254.0	21 000	279.4	10 500	21.6	43.2
DV	254.0	34 000	279.4	10 500	21.6	43.2
DV	304.8	21 000	346.1	10 500	44.7	85.9

Rockwell Manufacturing

MODEL OR TYPE	LINE SIZE mm	MAXIMUM WORKING PRESSURE kPa	BORE SIZE mm	HYDRAULIC OPERATION MAXIMUM kPa	LITRES TO CLOSE	LITRES TO OPEN
AC VALVE WITH U-1 HYD OPER	50.8	14 000	NA	17 300	0.5	0.4
	50.8	21 000	NA	17 300	0.5	0.4
	50.8	34 000	NA	17 300	0.5	0.4
	50.8	69 000	NA	17 300	0.8	1.8
	63.5	14 000	NA	17 300	1.0	0.9
	63.5	21 000	NA	17 300	1.0	0.9
	63.5	34 000	NA	17 300	1.0	0.9
	63.5	69 000	NA	17 300	1.7	1.6
	76.2	14 000	NA	17 300	1.1	0.9
	76.2	21 000	NA	17 300	1.9	1.7
	76.2	34 000	NA	17 300	1.9	1.7
	101.6	14 000	NA	17 300	2.6	2.3
	101.6	21 000	NA	17 300	2.6	2.3
	101.6	34 000	NA	17 300	3.9	3.7

Rucker Shaffer

MODEL OR TYPE	LINE SIZE mm	MAXIMUM WORKING PRESSURE kPa	BORE SIZE mm	HYDRAULIC OPERATION MAXIMUM kPa	LITRES TO CLOSE	LITRES TO OPEN
FLO-SEAL	50.8	21 000	52.4	21 000	0.8	0.8
FLO-SEAL	50.8 Reg	34 000	42.9	21 000	0.8	0.8
FLO-SEAL	50.8	34 000	52.4	21 000	0.8	0.8
FLO-SEAL	52.4	69 000	52.4	21 000	1.5	1.5
FLO-SEAL	52.4	104 000	52.4	21 000	1.5	1.5
FLO-SEAL	63.5	14 000	65.1	21 000	1.1	1.1
FLO-SEAL	63.5	21 000	65.1	21 000	1.1	1.1
FLO-SEAL	63.5	34 000	65.1	21 000	1.1	1.1
FLO-SEAL	76.2	14 000	79.4	21 000	1.1	1.1
FLO-SEAL	76.2	21 000	79.4	21 000	1.1	1.1
FLO-SEAL	76.2	34 000	79.4	21 000	1.1	1.1
FLO-SEAL	77.8	69 000	77.8	21 000	2.3	2.3
FLO-SEAL	101.6	21 000	103.2	21 000	3.0	3.0
FLO-SEAL	101.6	34 000	103.2	21 000	3.0	3.0
FLO-SEAL	103.2	69 000	103.2	21 000	4.9	4.9
FLO-SEAL	152.4	21 000	179.4	21 000	-	-

Rucker Shaffer

MODEL OR TYPE	LINE SIZE mm	MAXIMUM WORKING PRESSURE kPa	BORE SIZE mm	HYDRAULIC OPERATION MAXIMUM kPa	LITRES TO CLOSE	LITRES TO OPEN
FLO-SEAL WITH RAM LOCK	50.8 Reg	14 000	42.9		1.1	1.1
	50.8	14 000	52.4	21 000	1.1	1.1
	50.8 Reg	21 000	42.9	21 000	1.1	1.1
	50.8	21 000	52.4	21 000	1.1	1.1
	50.8 Reg	34 000	42.9	21 000	1.1	1.1
	50.8	34 000	52.4	21 000	1.1	1.1
	52.4	69 000	52.4	21 000	1.5	1.5
	52.4	104 000	52.4	21 000	1.5	1.5
	63.5	14 000	65.1	21 000	1.1	1.1
	63.5	21 000	65.1	21 000	1.1	1.1
	63.5	34 000	65.1	21 000	1.1	1.1
	76.2	14 000	79.4	21 000	1.5	1.5
	76.2	21 000	79.4	21 000	1.5	1.5
	76.2	34 000	79.4	21 000	1.5	1.5
	77.8	69 000	77.8	21 000	2.3	2.3
	101.6	21 000	103.2	21 000	3.0	3.0
	101.6	34 000	103.2	21 000	3.0	3.0
103.2	69 000	103.2	21 000	3.0	3.0	
152.4	21 000	179.4	21 000	-	-	
				21 000		

Rucker Shaffer

MODEL OR TYPE	LINE SIZE mm	MAXIMUM WORKING PRESSURE kPa	BORE SIZE mm	HYDRAULIC OPERATION MAXIMUM kPa	LITRES TO CLOSE	LITRES TO OPEN
DB	76.2	21 000	79.4	21 000	1.1	1.1
DB	76.2	34 000	79.4	21 000	1.1	1.1
DB	77.8	69 000	77.8	21 000	2.3	2.3
DB	101.6	21 000	103.2	21 000	3.0	3.0
DB	101.6	34 000	103.2	21 000	3.0	3.0
DB	103.2	69 000	103.2	21 000	4.9	4.9
DB	152.4	21 000	179.4	21 000	7.6	7.6

1070: Drilling with a Service Rig

Requirements

Where drilling operations are conducted with a service rig, an application to modify the drilling regulations is **not** required provided casing has been set to a sufficient depth allowing shut-in of the well and:

- As a minimum, the blowout prevention system must conform to the Class III Servicing Blowout Prevention Requirements
- A full-opening drill string safety valve in the open position and a device capable of stopping back flow, both of which can be stripped into the well, shall be maintained on the rig in a readily accessible location
- The driller must possess a valid well service control certificate issued by ESC, IWCF, IADC or an equivalent organization or a certificate as per *Directive 036*. However, the duty holder would have to submit a gap analysis to the AER (welloperations@aer.ca) for a determination of whether the training is equivalent. One additional representative must have a valid well control certificate and must be readily available to assist the crew with well control operations.

Note: if drilling more than 100 m or into more than one hydrocarbon-bearing formation, refer to section 23, “Drilling with a Service Rig and Servicing with a Drilling Rig,” in *Directive 036*.

- A device shall be installed and maintained to provide warning at the driller's position of a change of the level of fluid in the mud tank or of an imbalance in the volume of fluids entering and returning from the well. Alternatively, the circulating tank and pump shall be continuously manned
- Adequate precaution shall be taken during drilling operations for wells which may contain hydrogen sulphide. In addition, the surface handling of any sour gas shall be in accordance with Informational Letter IL 91-2.
- All provisions of the well licence will be adhered to, including sample requirements
- The appropriate Board area office must be notified at least 24 hours prior to commencing operations

1080: Coiled Tubing Requirements

Note:

From EUB Calgary, Drilling and Production Department

Contact department for requirements or document status.

1090: BOP Modification Submission

Requirements

Drilling operations that deviate from the requirements of Schedule 8 of the Oil and Gas Conservation Regulation, or do not meet the requirements of section 4, Part II of this guide (service rigs), require EUB approval. Applications shall include the following information:

- The proposed BOP stack configuration including manifold diagram
- A detailed discussion is to be included where any loss of functionality or redundancy from the Schedule 8 requirements is proposed. This discussion must include details of any proposed compensating features

Where additional drilling requirements of the Oil and Gas Conservation Regulations will be modified, supporting information must be included justifying these changes.

1100: Oilfield Waste Management Inspection Guidelines – Drilling Operations

1.0 Definitions

“Container” means any portable device which has a capacity that does not exceed 454 litres and is used to store oilfield waste.

“On-Site Facility” means a facility that is used solely to deal with waste generated on that property or related properties owned by the owner of the facility.

“Oilfield Waste” means an unwanted substance or mixture of substances that results from the construction, operation or reclamation of a well site, oil and gas battery, gas plant, compressor station, crude oil terminal, pipeline, gas gathering system, heavy oil site, oil sands site or related facility.

“Oilfield Waste Management Facility” means a facility consisting of any or all of the following: a waste processing facility, a waste storage facility, a land treatment facility, a landfill, an incinerator, or any other oilfield waste management technology or facility.

“Oilfield Waste Processing Facility” means a system or arrangement of tanks or other surface equipment collecting, storing, treating or disposing of oilfield waste material from any gas, oil, oilfield or oil sands operation especially for the purpose of hydrocarbon recovery.

“Recover” means extracting materials or energy from a waste for other uses.

“Recycle” means converting waste back into usable material.

“Reduce” means generating less waste through more efficient practices.

“Reuse” means reusing materials in their original form.

“Secondary Containment System” means a system to prevent contaminant migration which can consist of either a liner system or in the case of containers, an overpack system.

“Storage” means the holding of oilfield waste for a temporary period of time until the oilfield waste is transported, treated, or disposed.

“Tank” means a stationary device, designed to contain an accumulation of oilfield waste, which is constructed primarily of non-earthen, impervious materials that provide structural support and may include such materials as concrete, steel, plastic, or fibreglass. Tanks may be above ground, semi-buried or underground.

2.0 Waste Characterization

2.1 It is the responsibility of the waste generator (licensee of the well) to properly identify and characterize all oilfield wastes on site.

(a) The three major categories under which oilfield wastes may be characterized are as follows:

- Dangerous Oilfield Wastes
- Non-dangerous Oilfield Wastes
- Testing required to determine characteristics.

2.2 **As a minimum the company representative should have all of the following information readily available to show proper waste characterization.**

(a) **The type of wastes generated on site.**

(b) **The characteristics of these wastes.**

- **Dangerous**
- **Non-dangerous**

(c) **The volume of those wastes currently generated and stored on site.**

2.3 Refer to Table 1 of this appendices for listed Drilling Waste treatment and disposal information.

Note: For further and more detailed information see Section 5.0 of the “Recommended Oilfield Waste Management Requirements”.

3.0 Waste Storage

3.1 Storage of oilfield wastes on site may include:

(a) Above Ground tanks

- surrounded by a secondary containment (diked in accordance to Section 8.030 of the Oil and Gas Conservation Regulations), built of an impermeable material capable of withholding all forces when full to capacity and free of any drains that would provide leakage to the surrounding area.
- all tanks must be designed to contain oilfield wastes, and prevent any odour problems associated with vapour releases.
- properly designed to prevent spills when loading or unloading.
- *must be removed after the final drilling date of the well or during the lease clean up*

(b) Semi-buried or Underground Tanks

- adequately designed to contain oilfield wastes and prevent any odour problems associated with vapour releases.
- must be properly designed to ensure segregation from other wastes generated on site (particularly those characterized as dangerous).
- properly designed to prevent spills when loading or unloading.
- the use of underground or semi-buried tanks to store wastes during drilling operations will only be permitted where the process of collecting and storing those wastes dictates the need for a drainage system leading to the tank. (e.g. Boiler blowdown tank to ensure complete drainage from the vessel).
- underground tanks installed for the purpose of waste storage during drilling operations will not require leakage monitoring and corrosion prevention.

(c) Containers (barrels, drums, bins, etc.)

- (i) Liquid wastes stored in containers shall be placed in a structure that has the following:
 - a floor that will not absorb the waste.
 - has no drainage to sewers or the ground underneath the site.
 - loading and unloading areas that will limit and contain spills.

- a secondary containment system.
- (ii) Solid wastes stored in containers shall be placed in a structure that has the following:
 - side walls and a cover to protect the containers from the weather, or
 - a secondary containment system.

3.2 As a minimum the company representative should have all of the following information readily available to show proper storage of oilfield wastes.

- (a) The location of storage facilities, on site.**
- (b) The volume of wastes stored.**
- (c) Information and specifications on each storage facility to ensure that they meet the requirements outlined above.**

Note: For further and more detailed information see Section 7.0 of the “Recommended Oilfield Waste Management Requirements”.

4.0 Waste Disposal

4.1 The EUB emphasizes waste minimization through the 4 R's (reduce, reuse, recycle, recover). Prior to disposal of oilfield wastes the *licensee of the well* should be minimizing wastes generated by using these principles.

For routine inspection purposes we should encourage waste minimization and ensure proper disposal.

4.2 The disposal options may vary greatly from one well to another, generally there will be 4 categories of disposal under which the waste generators options could be categorized.

- (a) On Site Facilities - this would include disposal wells licensed by the EUB or land treatment facilities, landfills, septic fields, etc. that were licensed by AEP on the facility's clean water licence, and owned by the waste generator.
- (b) EUB Approved Facilities - this will include the Oilfield Waste Management Facilities listed in GB 93-15.
- (c) AEP or Alberta Health Approval Facilities - these facilities must be authorized to handle specific wastes.

- (d) One *time* Disposal Approvals - One time disposal options approved through the Area Offices or the Environment Protection Department. (e.g. Sump disposal in accordance with ID 93-1 and Guide G-50).

It is the responsibility of the generator to characterize their waste material and to ensure that the facility receiving their waste is approved to handle it. On the other hand, it is the responsibility of the facility operator to know the facility's capabilities and limitations and to disclose this information to the waste generators asking to use their facility.

Generators found sending their waste material to an unapproved facility or to an approved facility that is not authorized to accept that specific waste will be required to retrieve their wastes plus any other material contaminated by the waste.

4.3 As a minimum the company representative should have all of the following information readily available to demonstrate proper disposal of oilfield wastes.

- (a) **A list of all wastes generated and currently stored on site and the disposal plans** in place for these wastes.

4.4 Refer to attachment *Table 1 Drilling Wastes Treatment and Disposal Information*.

4.5 An excellent reference to proper disposal options for specific wastes in Section 7.0 "Waste Specific Information" of the CPA Production Waste Management Handbook.

5.0 Accounting and Documentation

5.1 Waste generators are responsible to account for wastes from their source to their final disposition.

- (a) Records showing the source, volume, and final disposition of wastes generated onsite and disposed of since 1 September 1993.

Note: For further more detailed information see Section 6.0 of the Recommended Oilfield Waste Management Requirements".

6.0 Summary

1. Waste Characterization — Types of wastes generated and their properties and characteristics. (Non-dangerous or dangerous).
2. Waste Storage — In accordance to Section 7.0 of the "Recommended Oilfield Waste Management Requirements".
3. Waste Disposal — Proper disposal with an emphasis on minimization.
4. Accounting — From the source of generation to the final disposition.

Table 1 Drilling Wastes Treatment and Disposal Information

The following waste streams have been characterized and classified based on historical knowledge, testing and in some cases the origin of the waste streams. In applying these characterizations, it is essential that generators examine their own wastes to determine if standard industry practices have resulted in the production of the waste and that their wastes fit the listed type. Any unusual operations, new process feedstock used or site specific conditions may result in a change in a waste's properties. If unusual properties are suspected to exist, then the general characterization method outlined in Section 5.1 of the ERCB's publication "Recommended Oilfield Waste Management Requirements" must be used.

This table contains treatment and disposal information. Other issues such as worker safety, material handling procedures, storage and transportation requirements should also be considered. References for these areas include the Canadian Association of Petroleum Producers' Production Waste Management Handbook, the Workplace Hazardous Materials Information System (WHIMS) and the Transportation of Dangerous Goods Regulations (TDGR).

The following headings are used within the table:

Waste Name - the generic name for a given waste stream

Class - the usual classification of the waste. Wastes are classified as Dangerous Oilfield Waste, Non-Dangerous Oilfield Waste, or Testing Required. This class is to be used when considering disposal options.

Dangerous Oilfield Waste: Some waste facilities may be prohibited from accepting Dangerous Oilfield Wastes. As well, if an oilfield waste is designated as Dangerous Oilfield Waste it is considered dangerous for the purposes of the Transportation of Dangerous Goods Act.

A generator whose waste is listed as Dangerous Oilfield Waste may choose to test the waste properties listed in the Criteria column and any other suspected dangerous properties based on the generator's knowledge of the waste. If the tests show the waste is Non-Dangerous Oilfield Waste, it may be classified as such.

Testing Required: Where Testing Required is indicated, either the waste is too variable in nature to confidently describe its typical properties or the historical information available at the present time is insufficient to definitively classify the waste. In these cases, the wastes should be tested for, as a minimum, the properties noted in the Criteria column, and evaluated against the dangerous properties defined in Section 5.2 of the ERCB's publication "Recommended Oilfield Waste Management Requirements" to determine the waste's proper classification.

See Comments: The Comments column gives direction on classification of the waste and properties of the waste to consider. These wastes are usually Non-Dangerous Oilfield Wastes.

Non-Dangerous Oilfield Wastes: These wastes usually are non-dangerous in nature.

Criteria - these are the properties that generally are of concern in Dangerous Oilfield Wastes or wastes classified as Testing Required. Generators may identify other properties of concern based on a site specific evaluation of their wastes.

Acceptable Industry Practices - these are practices accepted by industry, the EUB and AEP as a means by which the environmental and safety consequences of the waste may be appropriately managed. **In the case of Dangerous Oilfield Wastes or wastes where Testing is Required, the use of these practices do not result in the reclassification of the waste to Non-Dangerous Oilfield Waste. Dangerous Oilfield Wastes remain classified as Dangerous regardless of whether the Acceptable Practices are used or not, and all requirements for handling, manifesting, storage, etc. remain in effect.** The practices are seen as processes as a whole by which the dangerous properties are managed. Reclassification of the waste can only occur through waste treatment and testing or the use of an Approved Treatment Standard contained in Attachment C of the ERCB's publication "Recommended Oilfield Waste Management Requirements".

The practices described generally will be conducted at a facility approved by either the EUB or Alberta Environmental Protection. Other sections of the ERCB Guide to Oilfield Waste Management should be referenced to clarify the expectations, both operationally and for approval requirements, for a given disposal practice.

Comments - these are provided to give clarification to the previous columns, to give additional guidance as to waste properties of concern and other considerations.

This table will be reviewed and amended periodically. The next scheduled review is September 1995 or earlier as required.

References: ERCB "Recommended Oilfield Waste Management Requirements"
CAODC "Oilfield Waste Management Procedures"
CAPP "Production Waste Management Handbook" Section 7

Table 1 Drilling Waste Treatment and Disposal Information

WASTE NAME	CLASS	CRITERIA	ACCEPTABLE INDUSTRY PRACTICES	COMMENTS
Absorbent - used to control spills	See comments		<ul style="list-style-type: none"> • Store in a separate container • Thermal treatment • dispose of in an approved landfill 	<ul style="list-style-type: none"> - normally not a Dangerous Oilfield waste - This material may constitute a Dangerous Oilfield Waste depending on its leachate characteristics (esp. BTEX); if the BTEX level in this material > 1000 mg/kg, it is non-landfillable
Acid (non-neutralized), used for operations such as water treatment, cooling water inhibition, descaling operations and well servicing. Includes left over and spent acids.	Dangerous Oilfield Waste	corrosivity, heavy metals content, flash point (if hydrocarbons present)	adjust pH to between 4.5 and 12.5, then inject down an EUB approved Class Ia well or adjust pH to between 6.0 and 9.0 then inject down an EUB approved Class Ib disposal well, depending on the heavy metal content - hydrocarbons should be recovered	<ul style="list-style-type: none"> - ERCB Guide G-51 gives details on disposal well requirements - heavy metals normally are not concern for well servicing fluids
Batteries including lead acid and nickel cadmium types from vehicles, electric and lighting systems and instrumentation	Dangerous Oilfield Waste	pH < 2, corrosivity, leachate characteristics (heavy metals (esp. Pb, Cd))	<ul style="list-style-type: none"> - recycle via battery recyclers - remove free liquid from wet batteries and neutralize, landfill containers in an approved landfill 	<ul style="list-style-type: none"> - for alkaline batteries see Camp - Domestic Waste

Table 1 Drilling Waste Treatment and Disposal Information

WASTE NAME	CLASS	CRITERIA	ACCEPTABLE INDUSTRY PRACTICES	COMMENTS
Boiler Blowdown Water	See comments		For Dangerous Oilfield Waste <ul style="list-style-type: none"> - reuse - inject down an EUB approved Class Ia or Class Ib disposal well depending on heavy metal content For Non-Dangerous Oilfield Waste <ul style="list-style-type: none"> - reuse - inject down an EUB approved Class Ia Class Ib disposal well - test and retest it meets requirements for surface discharge 	<ul style="list-style-type: none"> - ERCB IL 94-2 and Guide G-51 give details on disposal well requirements - normally not a Dangerous Oilfield Waste - if this material contains Cr (VI) or other additives, it may constitute a Dangerous Oilfield Waste.
Cable	Non Dangerous Oilfield Waste		<ul style="list-style-type: none"> - Recycle - Landfill on an approved landfill 	<ul style="list-style-type: none"> - May be sold to other consumers for domestic uses - Cut into 1m lengths and landfill
Camp or Domestic Wastes	Non Dangerous Oilfield Waste		<ul style="list-style-type: none"> - Landfill in a Municipal landfill - Incinerate in accordance to ERCB IL 81-10 "Disposal of Campsite and Well Site Waste" 	<ul style="list-style-type: none"> - Must be stored at the campsite and segregated from the drilling rig generated waste
Containers Aerosol	See comments		<ul style="list-style-type: none"> - blowdown until completely empty and landfill in a Municipal landfill 	<ul style="list-style-type: none"> - May constitute a Dangerous Oilfield Waste if the aerosol container is not completely blown down and its contents was a substance listed in Part B of Table 4 of the Alberta Users Guide for Waste Managers

Table 1 Drilling Waste Treatment and Disposal Information

WASTE NAME	CLASS	CRITERIA	ACCEPTABLE INDUSTRY PRACTICES	COMMENTS
Containers (Empty) - Drums/Barrels, Crude Oil Sample Bottles	See comments		For Dangerous or Non-Dangerous Oilfield Waste <ul style="list-style-type: none"> - reuse (return to supplier) - recycle - rinse (see definition Section 5.2(2)(c), crush and landfill in an approved landfill (industrial, municipal) 	<ul style="list-style-type: none"> - normally not a Dangerous Oilfield Waste - drums/barrels must be completely empty; those drums/barrels that are not empty may be a Dangerous Oilfield Waste depending on their last contents
Containers - Paint and Brushes	See comments		<ul style="list-style-type: none"> - triple rinse, reuse and recycle where possible - Use completely, then leave can open in a ventilated area for residue to dry and harden. Once dry, deposit in garbage bin, lid off - Clean and reuse brushes. Once unusable, leave to harden and deposit in garbage bin 	May constitute a Dangerous Oilfield Waste depending on its flash point, ignitability and leachate characteristics if not rinsed, dried, and ventilated correctly
Containers - Pipe Dope and Brushes	See comments		<ul style="list-style-type: none"> - triple rinse and reuse or recycle where possible - once unusable, triple rinse and dispose of in an approved landfill 	May constitute a Dangerous Oilfield Waste based on leachate characteristics if not rinsed properly
Contaminated Soil - Hydrocarbons, Diesel, Hydraulic Fluids, Glycol	See comments		For Dangerous or Non-Dangerous Waste: <ul style="list-style-type: none"> - if land treatment on-site is not possible, excavate and send to licensed oilfield waste processing facility for hydrocarbon recovery - thermal treatment 	<ul style="list-style-type: none"> - normally not a Dangerous Oilfield Waste - this material may constitute a Dangerous Oilfield Waste depending on its flash point and BTEX content - treat on-site if possible, in consultation with EUB - all off-site spills or spills in excess of 2 m³ must be reported to the EUB

Table 1 Drilling Waste Treatment and Disposal Information

WASTE NAME	CLASS	CRITERIA	ACCEPTABLE INDUSTRY PRACTICES	COMMENTS
Corrosion Inhibited Water	Dangerous Oilfield Waste	heavy metals content	- inject down an EUB approved Class Ib disposal well if meets heavy metals limits; Class Ia well if exceeds limits	- ERCB Guide G-51 gives detail on disposal well requirements.
Drilling Sump Materials - Gel chem	Not a Dangerous Oilfield Waste		- treatment on-site, land treatment in accordance with ERCB ID 93-1	
Drilling Sump Materials - KCI	Not a Dangerous Oilfield Waste		- inject liquids down an EUB approved Class Ia or Class Ib disposal well, bury solids on-site in accordance with ERCB ID 93-1	- EUB approval for disposal of KCL sump materials must be obtained prior to spudding the well (see ERCB IL 93-6) - in some cases liquids may be land treated in accordance with ERCB ID 93-1
Drilling Sump Materials - Oil Base	See comments		For Dangerous or Non-Dangerous Oilfield Waste: - recycle liquids, land treat solids in accordance with ERCB ID 93-1 - thermal treatment	- normally not a Dangerous Oilfield Waste - this material may constitute a Dangerous Oilfield Waste depending on its flash point and BTEX content - EUB approval for disposal of invert sump materials must be obtained prior to spudding the well (see ERCB IL 93-6) - additives may render fluid unacceptable for re-refining.
Drill Stem Test Fluids - Hydrocarbon, Salt Water	Dangerous Oilfield Waste	flash point ignitability	- Contain and recover - Send for hydrocarbon recovery at an approved oilfield waste processing facility	

Table 1 Drilling Waste Treatment and Disposal Information

WASTE NAME	CLASS	CRITERIA	ACCEPTABLE INDUSTRY PRACTICES	COMMENTS
Filters	Dangerous Oilfield Waste	ignitability, flash point, spontaneous combustibility, leachate if in a friable form	<ul style="list-style-type: none"> - recycle (metal recovery) - thermal treatment - remove entrained liquids to standard as outlined in Attachment 5C, place in suitable container to prevent contact with air and landfill in an approved landfill 	<ul style="list-style-type: none"> - CAPP has developed sampling and testing protocol - recovered entrained liquid is a Dangerous Oilfield Waste and should be recycled, injected down an EUB approved Class Ia disposal well if organic fraction less than 10 per cent or incinerated
Frac Sand - Radioactive	See comments		<p>For Dangerous Oilfield Waste (Non-radioactive):</p> <ul style="list-style-type: none"> - recycle (return to supplier) - place in suitable container and landfill in an EUB approved Class I or II oilfield landfill or equivalent <p>For Non-Dangerous Oilfield Waste (non-radioactive):</p> <ul style="list-style-type: none"> - recycle (return to supplier) - bury on-site in accordance with AECB guidelines 	<ul style="list-style-type: none"> - radioactive materials must NOT be taken to a waste processing facility or road disposed - radioactive materials are regulated by the Atomic Energy Control Board. Approval from the AECB is required for off site transportation. - this material may constitute a Dangerous Oilfield Waste after radioactive decay due to leachate characteristics (heavy metals from radioactive tracers)
Glycol solutions (aqueous)	See comments		<p>For Dangerous or Non-Dangerous Oilfield Waste:</p> <ul style="list-style-type: none"> - recycle - inject in EUB approved Class Ia or Class Ib disposal well if glycol content less than 40% by mass. 	<ul style="list-style-type: none"> - normally not a Dangerous Oilfield Waste - this material may constitute Dangerous Oilfield Waste depending on its leachate characteristics, flash point and toxicity - ERCB Guide G-51 give details on disposal well requirements
Grease Cartridges (Empty)	Not a Dangerous Oilfield Waste		<ul style="list-style-type: none"> - dispose of in an approved landfill 	<ul style="list-style-type: none"> - completely empty cartridge - Clean with a rag or sorbent material

Table 1 Drilling Waste Treatment and Disposal Information

WASTE NAME	CLASS	CRITERIA	ACCEPTABLE INDUSTRY PRACTICES	COMMENTS
Hydrotest Fluids (Methanol)	Dangerous Oilfield Waste	ignitability, flash point, toxicity	<ul style="list-style-type: none"> - reuse - recycle - inject down an EUB approved Class Ia or Class Ib disposal well - thermal treatment 	<ul style="list-style-type: none"> - ERCB Guide G-51 gives details on disposal well requirements
Hydraulic Oil	Dangerous Oilfield Waste	<ul style="list-style-type: none"> - heavy metals - ignitability and flash point 	<ul style="list-style-type: none"> - recycle - reuse - thermal treatment 	<ul style="list-style-type: none"> - supplier may take back used product - Deliver to an used oil recycler
Lubricating Oil - Hydrocarbon	Dangerous Oilfield Waste	heavy metal content (esp. Ba), ignitability, flash point	<ul style="list-style-type: none"> - collect and direct to a licensed lube oil recycling firm - thermal treatment 	<ul style="list-style-type: none"> - supplier may take back used product
Lubricating Oil - Synthetic	Dangerous Oilfield Waste	heavy metal content, ignitability, flash point	<ul style="list-style-type: none"> - collect and direct to a licensed lube oil recycling firm - thermal treatment 	<ul style="list-style-type: none"> - supplier may take back used product
Mud sacks	Not a Dangerous Oilfield Waste		<ul style="list-style-type: none"> - recycle - dispose of to an approved landfill 	<ul style="list-style-type: none"> - collect in a segregated storage area and return them to the supplier

Table 1 Drilling Waste Treatment and Disposal Information

WASTE NAME	CLASS	CRITERIA	ACCEPTABLE INDUSTRY PRACTICES	COMMENTS
Rags - Oily	See comments		For Dangerous Oilfield Waste: <ul style="list-style-type: none"> - reuse via laundering/dry-cleaning - remove entrained liquids and landfill in an approved landfill - thermal treatment For Non-Dangerous Oilfield Waste: <ul style="list-style-type: none"> - reuse via laundering/dry cleaning - remove entrained liquids and landfill in an approved landfill (EUB, industrial or municipal) 	<ul style="list-style-type: none"> - normally not a Dangerous Oilfield Waste - this material may constitute a Dangerous Oilfield Waste depending on its flash point or ignitability if it is not hydrocarbon free or due to its leachate characteristics (esp. BTEX); if the BTEX level in this material >1000 mg/kg, it is non-landfillable - section 8.2 has information on oilfield landfill design requirements
Refuse - Planks, scrap metal, papers, plastics	ignitability, flash point, halogenated organic content	<ul style="list-style-type: none"> - recycle (regenerate, alternate uses) - thermal treatment 	<ul style="list-style-type: none"> - recycle - reuse - landfill 	
Solvents	Dangerous Oilfield Waste	ignitability, flash point, halogenated organic content	<ul style="list-style-type: none"> - recycle (regenerate, alternate uses) - thermal treatment 	
Thread Protectors	See comments		<ul style="list-style-type: none"> - recycle - thermal treatment - clean and landfill in an approved landfill 	<ul style="list-style-type: none"> - normally not a Dangerous Oilfield Waste - may constitute a Dangerous Oilfield Waste based on the lead content of the pipe dope - store in a separate bin or container and return to supplier or recycler

Table 1 Drilling Waste Treatment and Disposal Information

WASTE NAME	CLASS	CRITERIA	ACCEPTABLE INDUSTRY PRACTICES	COMMENTS
Water - Rig Wash	Not a Dangerous Oilfield Waste		<ul style="list-style-type: none"> - Reuse - inject down an EUB Class Ia or Class Ib disposal well - test and release if water meets surface discharge criteria 	Surface Discharge Criteria a) Chlorides - < 500 mg/l b) pH - 6 to 9 c) no visible hydrocarbon sheen d) landowner consent e) water must not be allowed to flow directly into rivers, creeks, or any other permanent body of water f) document and record discharge criteria and volumes

1. It is the generator's responsibility to ensure wastes are treated and disposed of correctly. This table is based on wastes produced through the use of standard industry practices. If unusual properties are suspected to exist or the characteristics are uncertain, the general characterization method outlined in Section 5.1 of the "Recommended Oilfield Waste Management Requirements".
2. This table contains treatment and disposal information. Other issues such as worker safety, material handling procedures, storage and transportation requirements should also be considered. References for these areas include the Canadian Association of Petroleum Producers' *Production Waste Management Handbook*, the Workplace Hazardous Materials Information System (WHMIS) and the Transportation of Dangerous Goods Regulations (TDGR). All requirements of the Transportation of Dangerous Goods Act must still be met.
3. The use of Acceptable Industry Practices does **not** result in the reclassification of a Dangerous Oilfield Waste or a waste indicated as Testing Required to a Non-Dangerous Oilfield Waste. See notes which precede table.